



Bureau
International
des Expositions

Logistics and Customs Guide







Unless otherwise expressly indicated by Expo 2020 Dubai®, copyright of the content of this Guide is owned by Expo 2020 Dubai. Any part or the whole of this Guide may not be copied, reproduced, republished, uploaded, posted, transmitted, or distributed for any purpose without the explicit prior written permission of the Organiser.

This is not a commercial document.

© Expo 2020 Dubai®

2018



BETTER TO
ARE · RESP

EXPO 2020
DUBAI UAE

Preface

Expo 2020 Dubai is committed to facilitating a seamless journey for all participants. The Organiser's proactive and robust approach to the logistics and customs operation will ensure a smooth movement of the participants' goods from point of origin to the Expo site prior to the event, replenishment during the Expo event, and reverse logistics upon conclusion of the event.

The Organiser has developed the **Logistics and Customs Guide** to provide guidance on the processes that participants are required to follow to undertake their logistics and customs activities. This document sets out to define all parts of the supply chain covering inbound and outbound transportation, customs clearance, warehousing, and distribution to the Expo site, along with onsite logistics services.

Guidance on construction logistics is provided in the Self-Build Pavilions Delivery Guide, Rented Pavilions Guide, and Assisted Pavilions Guide. The logistics and customs processes described in this document are aligned with the Bureau International des Expositions (BIE) Convention, the General Regulations and Special Regulations of Expo 2020 Dubai, and the applicable laws and regulations of the United Arab Emirates (UAE).

The content of this Logistics and Customs Guide is outlined in the accompanying table.

Chapter	Content
Chapter 1 Introduction to Logistics and Customs Processes	High-level description of the logistics and customs processes detailing the steps from import customs clearance through to decommissioning and documentation closure
Chapter 2 Sustainability	Sustainability strategy related to logistics operations
Chapter 3 Transportation into the UAE and Packaging	Guidelines on transporting goods into the UAE, handling of goods, packing/labelling/marketing of packages, and freight sanitation
Chapter 4 UAE Customs Clearance Processes	Declaration of goods, clearance from the tax authority, customs inspection, submission of permits, and completion of the customs declaration documents
Chapter 5 Warehousing	Guidelines on warehousing operations
Chapter 6 Final Stage of Delivery	Guidelines on site security, delivery booking, accreditation, visitor hours, and branding restrictions
Chapter 7 Reconciliation and Audit	Goods inventory, reconciliation, and audit processes
Chapter 8 Decommissioning and Load Out	Removal and dispatch of goods from the Expo 2020 Zone and the UAE
Chapter 9 Courier Import and Export	Import and export of courier consignments
Chapter 10 Passenger Import and Export	Import and export of passenger goods
Chapter 11 UPS: The Official Logistics Partner	Services offered by UPS to participants



Contents

Understanding Controls and Guides	IX	8	Decommissioning and Load Out	43
Acronyms, Abbreviations, Units, and Definitions	X			
1 Introduction to Logistics and Customs Processes	1			
1.1 Compliance with the Laws and Regulations	3		8.1 Planning of Load Out of Goods	45
1.2 Commitment to Safety and Service Excellence	3		8.2 Consolidated Declaration	46
1.3 The Logistics and Customs Journey	3		8.3 Scrap and Recycling	46
1.4 Setting Up the Logistics Operation	6		8.4 Export	46
1.5 Test Events	7		8.5 Reselling	47
2 Sustainability	9		8.6 Donation	47
2.1 Transportation of Goods	11		8.7 Giveaways and Gifts	47
2.2 Packaging	11		8.8 Documentation Closure	47
3 Transportation into the UAE and Packaging	13	9	Courier Import and Export	49
3.1 Transportation to Dubai, UAE	15		9.1 Courier Import	51
3.2 Freight Forwarding, Small Package, and Courier Services	16		9.2 Courier Export	51
3.3 Operational Procedure for Transport	16	10	Passenger Import and Export	53
3.4 Oversize Loads	16		10.1 Permitted and Duty-Exempt Goods	55
3.5 Handling of Dangerous Goods	16		10.2 Import	56
3.6 General Packaging Guidelines	16		10.3 Temporary Import	56
3.7 Labelling and Marking	17		10.4 Export after Temporary Import	56
3.8 Bonded Deliveries	18		10.5 ATA Carnet	56
3.9 Freight Sanitation Guidelines	18	11	UPS: The Official Logistics Partner	59
4 UAE Customs Clearance Processes	21		11.1 UPS' Global Logistics Services	62
4.1 Customs Declaration	24		11.2 Advantage of Engaging with UPS	62
4.2 Taxes	25		11.3 What UPS Offers for the Logistics of Construction Materials	62
4.3 Customs Inspections	26		11.4 Onsite Services	63
4.4 Prohibited and Restricted Goods	26		11.5 CarbonNeutral Programme	63
4.5 Goods that are Exempt from Customs Duties	26		Supporting Resources	65
4.6 Completion of Customs Declaration	27			
5 Warehousing	29			
5.1 Operational Procedure	31			
5.2 Storage of Packaging Materials	32			
6 Final Stage of Delivery	33			
6.1 Site Security	35			
6.2 Booking on DMS	36			
6.3 Accreditation	37			
6.4 Visitor Hours	37			
6.5 Branding Restrictions	38			
6.6 Receiving of Goods	38			
7 Reconciliation and Audit	39			
7.1 Goods Inventory and Reconciliation	42			
7.2 Customs Audit	42			



Understanding Controls and Guides

Throughout this document, two criteria for compliance — controls and guides — have been established to assist the participants in their logistics and customs operation.

Controls are ‘must’ statements that establish the compulsory logistics and customs requirements for all participants taking part in Expo 2020 Dubai to ensure that the standards and aspirations are achieved for the benefit of all parties as a whole.

Guides are ‘can’ or ‘should’ statements that describe methods or suggested ways of operating that meet the specified goals and objectives of Expo 2020 Dubai.

Each control and guide is assigned a unique alphanumeric code. The first character of the code identifies if the statement is a control (**C**) or a guide (**G**). The numeric character identifies the sequential order of the control or guide. For example, in the accompanying figure, **C-07** is a control while **G-01** is a guide.

The controls and guides will facilitate the Organiser in assessing the participants’ compliance with Expo 2020 Dubai’s logistics and customs standards and requirements. These will also help the participants in:

- › Managing and aligning their logistics plans and operations in line with the requirements of the Organiser, UAE Customs, and other relevant authorities
- › Ensuring compliance with the laws and regulations established by the UAE Government in relation to customs clearance, handling of goods, and rates and charges imposed on imported goods
- › Communicating their requirements to their logistics providers, suppliers, and subcontractors in a consistent way

Example of a Control Statement

C-07

Participants must ensure that the final destination specified in all of their shipping documents and cargo labels is Dubai, regardless of ports of transit in the UAE.

Example of a Guide Statement

G-01

Participants should instruct their logistics provider to request that the shipping line places their container on the top tier of the load, at origin, to expedite discharge at the destination.

Acronyms, Abbreviations, Units, and Definitions

Acronyms and Abbreviations

Acronym/Abbreviation	Expansion
ASN	Advance Shipping Notice
ATA	Admission Temporaire/Temporary Admission
BIE	Bureau International des Expositions
CD	Compact Disc
CIF	Cost, Insurance, and Freight
CMR	Convention Relative au Contrat de Transport International de Marchandises par la Route
DMS	Delivery Management System
DVD	Digital Video Disc
FTA	Federal Tax Authority
GCC	Gulf Cooperation Council
IATA DGR	International Air Transport Association Dangerous Goods Regulations
IMDG	International Maritime Dangerous Goods
IPPC	International Plant Protection Convention
ISO	International Organisation for Standardisation
ISPM	International Standards for Phytosanitary Measures
IT	Information Technology
RSA	Remote Screening Area
SKU	Stock Keeping Unit
TRN	Tax Registration Number
UAE	United Arab Emirates
UPS	United Parcel Service, Inc.
VAT	Value-Added Tax
VSA	Vehicle Screening Area

Units

Unit	Expansion
AED	United Arab Emirates Dirham
cm	Centimetre
ft	Feet
g	Gram
kg	Kilogram
L	Litre
m	Metre
mL	Millilitre
mm	Millimetre

Definitions

Term	Definition
Abnormal Load	A load that is extra long or extra wide and that requires a special logistics arrangement, such as a vehicle escort or a temporary reconfiguration of a route (widening of road), prior to delivery.
Accreditation	The pass that is issued by the Organiser to the participants and their workforce, granting them access to the Expo site and to specific areas within the site.
Accreditation Guide	A document developed by the Organiser and issued to participants to guide them on the accreditation process.
Advance Shipping Notice	An electronic notification that is received by a consignee regarding an impending shipment receipt (usually with 7 to 30 days' notice); also referred to as Inbound Advice Notification.
Air Waybill	A document that is used for domestic and international air and land transportation of goods to a specified destination.
Assisted Pavilions Guide	A document developed by the Organiser and issued to participants to provide them guidance on the standards, requirements, and best practice recommendations on the delivery of their exhibits in their Thematic District Pavilions.
ATA Carnet	An international customs and temporary import-export document that is issued by the Chamber of Commerce at the country of origin of the goods.
BIE Convention	The Paris Convention of 22 November 1928 relating to international exhibitions as amended and supplemented.
Bill of Lading	A document that is issued by a ship carrier (or its agent) as an acknowledgement that the goods have been loaded and as a receipt of cargo for shipment.
Bonded Deliveries	Consignments that are duty-free and are moved from one duty-free location to another. Bonded deliveries are subject to Customs' sealing and documentation processes.
Branding Restrictions	The restrictions imposed at certain times on participants' logistics providers in terms of vehicle branding to protect the Official Logistics Partner of Expo 2020 Dubai.
Calendar Day	All days in a month, including weekends and holidays.
Carbon Footprint	The amount of carbon dioxide equivalent emitted due to the consumption of fossil fuels during the transportation to/from the Expo site.
Carbon Offsets	Certified and auditable credits for carbon dioxide equivalent reductions achieved by one party, that can be purchased and used to compensate the emissions of another party according to the rules laid out in the Kyoto Protocol.
Cargo	Goods, materials, or merchandise carried on-board an aircraft, ship, train, or truck for which an Air Waybill, Bill of Lading, or other receipt is issued by the carrier.
Certificate of Origin	An international trade document confirming that the goods in a particular shipment have been wholly obtained, produced, manufactured, or processed in a particular country.
CIF Value	The amount that a seller pays for costs, freight, and insurance against the risk of loss or damage of the buyer's goods while in transit to its destination.
CMR	Convention Relative au Contrat de Transport International de Marchandises par la Route; a consignment note and an international agreement that contains the rights and obligations of parties involved in road transport.
Commercial Invoice	A document that is issued by the seller, addressed to the buyer, giving details of the individual transaction including complete description of the goods, prices, currency, delivery, and payment terms.
Consignee	The entity who is financially responsible (the buyer) for the receipt of a shipment.
Consignment	When the consignor (the seller) sends goods to the consignee (the buyer).
Consolidated Declaration	Multiple shipments that are declared as one, adhering to the regulations of Customs.
Construction Logistics	The services that support the construction of the build environment.
Container	A unit load device with strength suitable to withstand shipment, storage, and handling over a period of time.
Country Manager	The Organiser's representative appointed to provide support to the participants and communicate the Organiser's requirements throughout the development of their pavilions.
Courier Service	A door-to-door, local or international, pickup and delivery service.
Customs Broker	A person or corporation licensed to handle the clearing process of goods through Customs on behalf of the importer.
Customs Claim Submission	The request to process a refund against a customs deposit.

Definitions

Term	Definition
Customs Clearance	The preparation and submission of documentation required to facilitate imports into or exports from the country.
Customs Codes	Two unique codes that are issued by Customs to the participants whose Expo 2020 licence permits them to import and export goods.
Customs Duty	A tax, duty, or tariff levied, at the time of import, on goods entering a country.
Customs Free Zone Bill of Transit-In	An electronic or manual Customs-approved form wherein the importer declares the goods in detail in accordance with the free zone regulations of Customs.
Customs Inspection	An official inspection conducted by Customs.
Customs Regulations	The rules or directives made and maintained by a customs authority in line with the government agreements and international laws in a particular country.
Customs Tariff	A classification of duties and other charges assessed by Customs via a harmonised commodity description and coding system.
Dangerous Goods	Materials that can cause harm to people, other living organisms, property, or the environment if not handled correctly, and that are subject to the regulations of the International Air Transport Association during the movement of goods.
Declaration Fee	The fee levied to a declaration statement made in the manner prescribed by Customs.
Decommissioning	The removal of the contents of a pavilion and of any relevant construction materials after the conclusion of the Expo event.
Delivery Access Protocols	The official procedures that delivery and collection vehicles must abide by before entering the Expo site during lockdown.
Delivery Advice	A document that is prepared by a free zone shipper under their letterhead, wherein complete commodity details are listed along with the Import Customs Declaration Reference.
Delivery Management System	The management tool that is used to regulate and schedule vehicle access to the Expo site.
Delivery Note	A document that accompanies a shipment providing details of the goods within the shipment (such as description and quantities) and details of the shipper and the consignee.
Delivery Order	A document from an owner, their agent, or a logistics provider that orders the release of goods to a consignee.
Documentation Closure	The final documentation process that results in Dubai Customs providing the participants with the non-liability certificate.
Dubai Integrated Energy Strategy 2030	The strategy outlined by the Dubai Supreme Council of Energy setting a target of a 30 percent reduction in energy consumption by the year 2030.
Embargoed Country	A country that is impacted by a variety of trade embargoes and economic sanction programmes that are administered by specific countries.
Euro Pallet	The standard European pallet as specified by the European Pallet Association.
Event Time	The defined period between 20 October 2020 and 10 April 2021.
Excise Tax	A form of indirect tax that is levied on specific goods which are typically harmful to human health or to the environment.
Excise Tax Import Declaration	A type of declaration that is processed when importing goods where excise tax is applicable.
Exit Certificate	A certificate that confirms the exit of goods from a country. An exit certificate is certified by Customs at the exit point.
Exit Protocols	The official procedures that delivery and collection vehicles must abide by before exiting the Expo site.
Expo 2020 Bid Dossier	The dossier submitted by the UAE to the BIE to host the World Expo in 2020.
Expo 2020 Dubai®	The international registered exhibition that will be held in Dubai, United Arab Emirates in 20 October 2020; also referred to as 'Expo 2020,' 'Expo,' 'Dubai Expo 2020,' 'Expo Dubai 2020,' or 'Expo event.'
Expo 2020 Licence	A trade licence issued by the Organiser to facilitate the operations of the participants in the UAE including but not limited to the import, export, sale, distribution, and storage of goods.
Expo 2020 Zone	A 'free zone' equivalent status granted by the UAE Government to the Organiser to facilitate all the regulatory requirements for the participants as provided in the Expo 2020 Bid Dossier.
Expo Commissioner General	The Commissioner General of Expo 2020 Dubai appointed in accordance with Article 12 of the BIE Convention.
Expo Site	The gated area on which Expo 2020 Dubai will be hosted; also referred to as 'site.'

Definitions

Term	Definition
Final Destination	The physical location of the final place at which the participants' goods will be delivered to.
Final Stage of Delivery	The last phase of a delivery to its final destination onsite.
Free Zone	An area within a country where imported goods can be stored or processed without being subject to customs duty, however, they are subject to customs procedures and regulations.
Free Zone Transit-In Declaration	A type of declaration that is processed when importing goods into a free zone from the rest of the world.
Free Zone Transit-Out Declaration	A type of declaration that is processed when exporting goods out of a free zone to the rest of the world.
Full Container Load	All goods in a container are listed in one Bill of Lading and, as such, are owned by one party.
GCC Common Customs Law	The unification of the customs regulations and procedures in the Gulf Cooperation Council (GCC) member states.
General Regulations	The general regulations of Expo 2020 Dubai that are included in Chapter 9 of the Registration Document as approved by the BIE General Assembly.
General Transportation Plan	A summary plan that provides an overview of the transportation of the participants' goods and inventory to or from Dubai.
Goods	The inventory or materials that may be distributed or moved to a final location for use, circulation, or consumption.
Harmonised Code	A universally accepted classification system for trade goods, used to classify products and their corresponding payable customs duties.
Hazardous Materials	An item or chemical that poses a potential risk to public safety or the environment when it is being transported or stored.
HazMat Code	A four-digit United Nations number that is used to identify a hazardous material.
Heat Treatment of Wood	A process whereby wood is heated in a closed chamber for at least 30 minutes, until it reaches a core temperature of 56°C, to kill insects, fungi, or pathogens.
Hookah	An instrument that is used for vaporising and smoking flavoured tobacco.
Incoterms	A series of pre-defined commercial terms that are common in international transport contracts.
Individual Shipment Transportation Plan	A specific transportation plan that details the timing, sequence, size, and vehicle type of each delivery associated with the load-in, replenishment, and load-out of the participants' pavilions.
Insurance Guide	A document developed by the Organiser and issued to participants to guide them on the specific requirements and key points of consideration when arranging insurances for Self-Build Pavilions and Rented Pavilions.
International Air Transport Association Dangerous Goods Regulations	The international guideline for the safe transportation or shipment of dangerous goods or hazardous materials by air on an aircraft.
International Maritime Dangerous Goods Code	The international guideline for the safe transportation or shipment of dangerous goods or hazardous materials by water on a vessel.
Inventory	Goods or materials in stock that can be compiled into an inventory list and which can be distributed or moved to a final location for use or circulation.
Inventory List	An electronic record-keeping associated with inventory.
ISO Country Code	The defined code for the names of countries, dependent territories, and special areas of geographical interest, published by the International Organisation for Standardisation (ISO).
ISPM 15	An International Phytosanitary Measure developed by the International Plant Protection Convention that directly addresses the need to treat wooden materials of a thickness greater than 6 mm.
Less-than-Container Load	A load that is insufficient in weight and/or size to fill the entire capacity of a shipping container.
Light Assembly	A special logistics service involving the rework of inventory so that it can be easily handled on receipt at destination. Light assembly includes relabelling, sorting components into a specific order, and assembly of components.
Load In	The physical movement of inventory onto the Expo site to a defined location pre-event time.
Load Out	The physical movement of inventory out of the Expo site post-event time to its final destination.
Lockdown	The stage in the life cycle of the Expo event during which a phased security sweep will take place and, after which, all access control measures will come into effect for the event phase.

Definitions

Term	Definition
Logistics Coordination Centre	A central point of contact for the logistics operation during the entire life cycle of the Expo event.
Logistics Provider	An entity that provides management over the flow of goods and materials from points of origin to end-use destination. The logistics provider handles shipping, inventory, warehousing, packaging, security, and other related logistics functions for shipments.
Manifest	A document that lists the cargo, passengers, and crew of a ship, aircraft, or vehicle, for the use of customs, ports, and other official authorities.
Marine/Goods in Transit Insurance	Insurance that provides coverage for property and goods against loss or damage while in transit by air, ocean, or road.
Material/Serial Number	A unique number that identifies an item.
Mechanical Handling Equipment	Equipment, such as forklifts or reach trucks, used in lifting and manoeuvring bulk quantities of inventory.
Methyl Bromide Fumigation of Wood	A process whereby wood is stacked in a sealed chamber and sprayed with methyl bromide to kill insects, fungi, or pathogens.
Non-Liability Certificate	A certificate that is issued by Customs to the participants to identify that no dues are outstanding under their name.
Non-Visitor Hours	The hours at which visitors are unable to access the Expo site during the event.
Official Logistics Partner	The logistics provider that is selected and appointed by the Organiser as an official partner of Expo 2020 Dubai.
One-Stop Shop	The virtual and physical entity that has been set up as a single body to process and respond to all submissions and requests from participants through a single window (the Participant Portal). The One-Stop Shop is integrated with statutory authorities and will facilitate all participants' interactions from initiation through to decommissioning.
Organiser	Bureau Expo Dubai 2020, established by the virtue of Decree No. 30 of 2014 issued on 25 June 2014 to administer the organisation and delivery of Expo 2020 Dubai.
Oversize Load	A load that exceeds the standard or permitted size and/or weight limits defined by the logistics provider, depending on the mode of transportation.
Paan	A mixture of betel leaf, areca nut, and tobacco.
Packing List	A list of the contents of a consignment including product descriptions, quantities, harmonised codes, delivery locations, and special instructions.
Pallet	A platform that is used to consolidate bulk material to enable more efficient handling and transportation.
Part Number	A unique reference by which a type of inventory is referred to.
Participant Portal	A web-based portal that facilitates communication between the participants and the One-Stop Shop.
Participants	Countries and multilateral organisations who have received and accepted the official invitation from the Government of the United Arab Emirates to participate in Expo 2020 Dubai. Participants also include those parties who have been authorised by the Expo Commissioner General to participate in the Expo event.
Participation Contract	The contract agreed upon between a Section Commissioner General and the Organiser to establish the terms and procedures by which the participants will take part in Expo 2020 Dubai.
Post-Event Phases	The phases after the conclusion of the Expo event: decommissioning and removal phase for Self-Build Pavilions and Rented Pavilions, and exhibit removal phase for Thematic District Pavilions.
Pre-Event Phases	The phases of pavilion delivery before the Expo event: design phase and construction phase for Self-Build Pavilions and Rented Pavilions, and design phase and exhibit installation phase for Thematic District Pavilions.
Prohibited Goods	Goods that cannot be imported, exported, or transited into the country.
Proof of Export	Customs-stamped documentation confirming the export of goods out of the country.
Public Holiday	A holiday that is generally established by law and is usually a non-working day for businesses during the year.

Definitions

Term	Definition
Rate Card	The information that describes the services available to the participants and the prices for those services. Rate cards are available on the Participant Portal.
Reconciliation of Goods	The customs process required to ensure that the goods entering and exiting the Expo 2020 Zone are updated in an inventory for stock checking and auditing purposes.
Registration Document	The registration document submitted to the BIE General Assembly as approved in the 158th General Assembly.
Remote Screening Area	An area offsite where delivery and collection vehicles, their contents, and their drivers are checked to ensure that they are authorised to enter the Expo site.
Rented Pavilions	Pavilions that are built by the Organiser and rented out to participants.
Rented Pavilions Guide	A document developed by the Organiser and issued to participants to provide them guidance on the standards, requirements, and best practice recommendations on the planning, design, and fit-out of their Rented Pavilions.
Repacking of Goods	The process of placing goods back into their original packaging (such as flight cases) or repackaging goods into newly supplied packaging to make ready for outbound logistics.
Replenishment	The regular restock and resupply of goods to a venue, compound, or pavilion, and in quantities agreed upon by the consignee.
Restocking of Goods	The delivery of supplies to replenish goods which are consumed, sold, or given away.
Restricted Goods	Goods which are required to meet certain conditions, such as the completion of permits, before clearance through Customs can be obtained.
Resupply of Goods	See <i>Restocking of Goods</i> .
Reverse Logistics	The full process flow of moving goods from the original final destination out of the site during or after the conclusion of the Expo event.
RISE™ Sustainable Operations Standards and Guidelines	A document developed by the Organiser based on the RISE (Respect, Impact, Safety, Environment) methodology of Expo 2020 Dubai outlining the standards, guidelines, and best practice recommendations to drive sustainability across all operations on the Expo site.
Section Commissioner General	The Section Commissioner General of a participant appointed in accordance with Article 13 of the BIE Convention.
Section Staff	The staff of the Section Commissioner General, the deputy of the Section Commissioner General, the pavilion director, and the other direct employees of the Section Commissioner General.
Sector	A group of venues within a zone with similar operational requirements and located in close proximity.
Security Sweep	The process by which a space or external area is checked against security criteria. After a security sweep has taken place in a space, then that space will be deemed to be 'clean' and will have strict entry criteria.
Self-Build Pavilions	Pavilions that are built by the participants.
Self-Build Pavilions Delivery Guide	A document developed by the Organiser and issued to participants to provide them guidance on the standards, requirements, and best practice recommendations on the construction and delivery of their Self-Build Pavilions.
Service Levels	The speed of response to a request given the time of day, nature of request, and other criteria.
Small Package Service	The transportation of packages that are generally less than 70 kg.
Special Days	Days that include major global holidays and/or days with enhanced entertainment and events such as Expo 2020 Dubai's opening and closing ceremonies, UAE Golden Jubilee Celebrations, Diwali, New Year's eve, and Chinese New Year.
Special Regulations	The Special Regulations listed in Article 34 of the General Regulations.
Standard Pallet	A flat transport structure that supports goods and allows handling and storage.
Stock Keeping Unit	A unique number assigned to a product.
Stock Keeping Unit (SKU) List	The master record of all SKUs that a participant will exhibit, store, consume, or sell as part of their participation in Expo 2020 Dubai.
Sustainability Policy	A policy that outlines Expo 2020 Dubai's commitment to practices and standards that promote environmentally responsible operations and drive sustainable outcomes in order to meet the overarching sustainability objectives for the Expo event.

Definitions

Term	Definition
Tax Registration Number	A number allocated by the UAE Federal Tax Authority to registered companies and traders for the purpose of filing tax.
Temporary Admission Customs Bill	A type of customs bill that is processed when goods are temporarily admitted for a certain purpose and for a specific period, with the suspension of customs duties levied on them until the purpose for which they have been admitted is terminated, if cash or bank guarantee equivalent to the payable customs duties is submitted.
Test Events	A series of scenarios and events that are designed to test the procedures that have been developed for Expo 2020 Dubai.
Thematic District Pavilions	Pavilions that are built by the Organiser and allocated to participants.
Trailer	A large van or wagon drawn by an automobile, truck, or tractor, used especially in hauling freight by road.
Transit-In Declaration	A type of declaration that is processed by the designated clearing agent against the assigned business. The commercial invoice must be declared at a line item level along with the accurate harmonised code, country of manufacture, and other relevant information that is declared in shipping.
Transit-Out Declaration	A type of declaration that is processed by the designated clearing agent against the assigned business. The commercial invoice must be declared at a line item level along with the accurate harmonised code, country of manufacture, and other relevant information that is declared for shipping.
UAE Customs	The Federal Customs Authority of the United Arab Emirates including Abu Dhabi Customs, Dubai Customs, Sharjah Customs, Ajman Customs, Umm Al-Quwain Customs, Ras Al-Khaimah Customs, and Fujairah Customs.
UAE Vision 2021	The national vision that outlines the challenges that the UAE will face in the future and provides an overarching perspective on mitigation over the coming years. The strategy focuses on economic, social, and environmental factors.
Value-Added Tax	A tax on the consumption or use of goods, levied at the point of sale along each step of the supply chain.
VAT Import Declaration	A type of declaration that is processed when importing goods where VAT is applicable.
Vehicle Screening Areas	The last checkpoint before a vehicle enters the Expo site to ensure that the vehicle, driver, and consignment are all authorised.
Venue	An operational physical location found onsite or offsite.
Visitor Hours	The hours at which visitors are able to access the Expo site during the event.
Waste Hierarchy Framework	The strategic approach to prioritising waste management, evaluating methods to first reduce, then reuse, and subsequently recycle products.
Wood Debarking	The process of removing bark from wood.
Working Days	All official business days of the week, excluding public holidays and weekends. In the UAE, the official business days are from Sunday to Thursday. All Fridays and Saturdays are considered weekends.
Zone	An operational area that breaks the Expo site into a set of smaller, more manageable operations, containing a number of venues.



1 Introduction to Logistics and Customs Processes

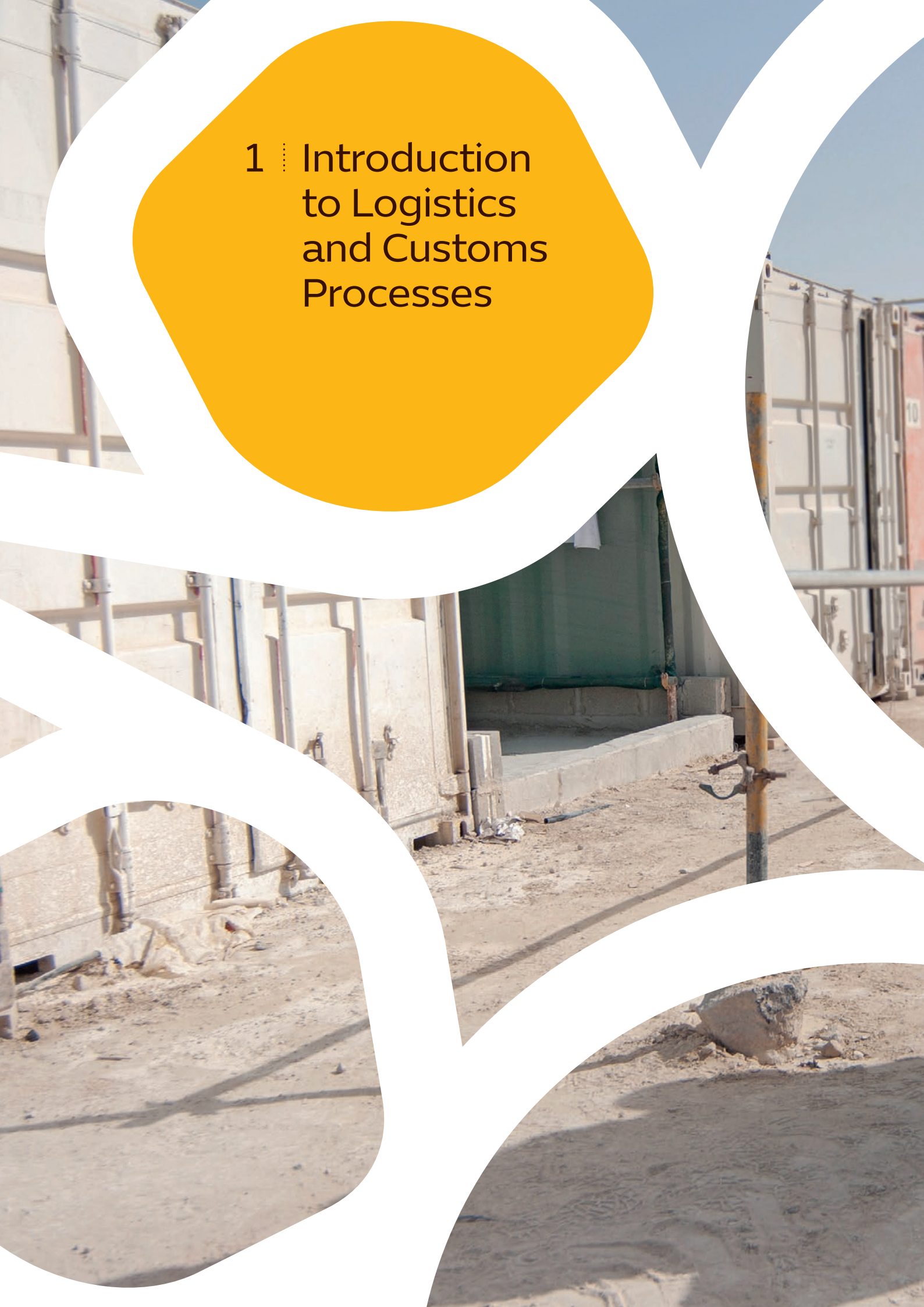



Expo 2020 Dubai aims to create a unique and memorable World Expo that is safe, innovative, collaborative, and sustainable. To help achieve this goal, the Organiser will ensure a seamless logistics and customs experience for all participants.

This introductory chapter provides a high-level overview of the participants' logistics and customs journey and explains how this journey is aligned with the different phases of pavilion delivery and removal. Subsequent chapters will cover each key component of the logistics and customs journey in detail.

1.1 Compliance with the Laws and Regulations

Participants are required to comply with the customs laws and regulations of the United Arab Emirates (UAE), the provisions of the BIE Convention, and any additional instructions or directives issued by the Organiser including but not limited to the General Regulations and Special Regulations of Expo 2020 Dubai.

1.2 Commitment to Safety and Service Excellence

The Organiser aims to provide a safe and secure environment for all visitors and workforce of Expo 2020 Dubai. This objective aligns with Expo 2020 Dubai's commitment to ensuring that everyone goes home in a safe and healthy condition every day. The Organiser has developed a Health and Safety Assurance Standards document which describes the operational practices and health and safety standards that need to be adopted by the participants and their supply chain throughout their journey. The Health and Safety Assurance Standards document is available on the Participant Portal.

In line with the nationwide effort of the UAE Government to promote service excellence, and through the collaboration with the UAE Federal Customs Authority, the local customs authorities, and Dubai Customs specifically, the Organiser is committed to providing an exceptional level of service to all participants throughout their journey. To deliver on this commitment, the Organiser has established the One-Stop Shop to provide full support to the participants. The One-Stop Shop is a virtual and physical entity that has been set up as a single body to process and respond to all submissions and requests from participants through the Participant Portal. The Logistics Coordination Centre will be established to facilitate logistics-related matters and monitor the Organiser's warehousing, distribution, venue, customs, freight, and logistics IT systems.

1.3 The Logistics and Customs Journey

Participants will commence their logistics and customs journey as early as the construction phase and continue through to the decommissioning phase. The participants' logistics and customs journey entails several key stages including clearance of imported goods through UAE Customs, storage of goods in a warehouse, delivery of the goods to the Expo site, and replenishment of goods during the Expo event. Reconciliation, export customs clearance, and documentation closure will occur at any time during the event or the decommissioning phase. The participants' logistics and customs journey is depicted in Figure 1.1.

The Organiser will work in close collaboration with the participants regarding their logistics and customs activities to ensure efficient and timely delivery of their goods.

Figure 1.1 Logistics and Customs Journey



1.3.1 Licensing and Registration

Once the participants have signed the Participation Contract and appointed the Section Commissioner General, the Organiser will provide them with the following:

- > **Expo 2020 Licence:** A trade licence issued by the Organiser to facilitate the operations of the participants in the UAE including but not limited to the import, export, sale, distribution, and storage of goods.
- > **Customs Codes:** Two unique identification codes that are specifically created for participants of Expo 2020 Dubai to distinguish them from other business entities in the UAE and to help ease customs clearance procedures:
 - Local Market Customs Code (to be used for commercial goods)
 - Free Zone Customs Code (to be used for non-commercial goods)

Each participant is eligible for one local market customs code and one free zone customs code only.

- > **Tax Registration Number (TRN):** A registration number through which the UAE Federal Tax Authority (FTA) will be able to recognise or identify a participant. This number will be linked to the customs codes to enable a deferred tax payment for imported goods.

Participants may only commence their logistics and customs operation in the UAE once they have received their Expo 2020 licence, which is accompanied by their corresponding customs codes, and TRN.

1.3.2 Logistics and Customs Technical Sessions

The Organiser will engage with the participants, through the Country Managers and the Participant Portal, to set up and run logistics and customs technical sessions. These sessions are mandatory for the logistics managers or their deputies and will focus on ensuring that the participants understand the logistics and customs clearance processes. Technical sessions are meetings that will commence once the Expo 2020 licence is issued to the participants.

1.3.3 Import Customs Clearance

The UAE has granted special benefits to Expo 2020 Dubai and its participants. This preferential treatment exempts participants from customs duties as long as their goods are in the Expo 2020 Zone.

1.3.4 Warehousing

Participants are responsible for managing the procurement and storage of their goods. These goods may be delivered directly to the Expo site or via a warehouse.

Storage services will be available for the load-in period before the Expo event and for replenishment during the event on a rate card basis.

1.3.5 Delivery Booking

The Organiser recognises that regulated access to the Expo site is important for participants. To achieve this, the Organiser will utilise an online Delivery Management System (DMS) to control the access of delivery and collection vehicles to the Expo site from the construction phase through to the decommissioning phase. The DMS is accessed via the Participant Portal.

Figure 1.2 Licensing and Registration

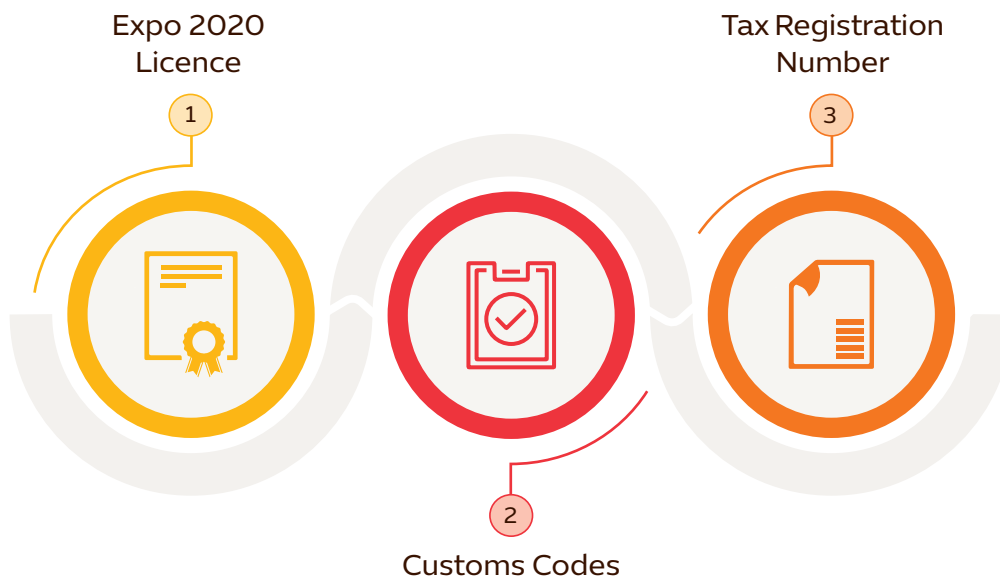

1.3.6 Delivery Screening

The Delivery Access Protocols are the procedures by which delivery and collection vehicles need to adhere to prior to entering the Expo site. Delivery Access Protocols will evolve over time and details will be provided to the participants through their Country Managers and via the Participant Portal.

There are two layers of security screening for vehicles accessing the Expo site:

- › Offsite Remote Screening Area (RSA)
- › Onsite Vehicle Screening Areas (VSAs)

Vehicles will be screened at the RSA. Once cleared at the RSA, vehicles will then pass through the assigned VSA on the Expo site. Refer to Figure 6.2.

1.3.7 Final Stage of Delivery Onsite

Participants need to consider how their deliveries will be offloaded from the vehicle and that there will be a requirement for their logistics manager or representative to receive the goods, sign for them, and check against their relevant documentation. See Section 1.4. Detailed information on site access and vehicle restrictions is available in Chapter 6.

1.3.8 Resupply, Replenishment, and Restock of Goods

Participants are responsible for managing the resupply, replenishment, and restock of their goods. To help ensure a seamless logistics operation across the site, participants are encouraged to efficiently plan their resupply, replenishment, and restocking activities during the Expo event. Participants also need to factor in the site booking and time period restrictions when planning the resupply of their goods.

1.3.9 Reconciliation and Export Customs Clearance

Goods that are imported into the Expo 2020 Zone are required to be recorded by the participants in their own goods inventory system. Periodically reconciling the inventory will help ensure a smooth export customs clearance.

1.3.10 Decommissioning and Documentation Closure

The Organiser aims to efficiently repurpose, recycle, and dispose of all its physical assets after the conclusion of the Expo event through a coordinated plan.

Participants' load out plans will play a key role in the successful decommissioning of the site. See Section 8.1

Participants need to complete their decommissioning activities no later than 10 October 2021 for Self-Build Pavilions or 10 July 2021 for Rented Pavilions and Thematic District Pavilions.

1.4 Setting Up the Logistics Operation

To ensure clear and consistent planning and communication between the Organiser and the participants, it is important that the latter designates a point of contact to supervise their logistics activities during the event.

C-01 Participants must appoint a logistics manager and a deputy logistics manager (if required) within their organisation, and inform the Organiser of the name, address, and contact information of their appointees in a letter from the Section Commissioner General. The Organiser must be informed of any changes made to the appointed logistics manager and deputy logistics manager.

1.4.1 Selecting a Logistics Provider

Participants may utilise the services of Expo 2020 Dubai's Official Logistics Partner, UPS Middle East FZE. Alternatively, participants are free to choose their own logistics provider.

1.4.1.1 UPS: The Official Logistics Partner

Expo 2020 Dubai recognises that common and complex challenges may be solved by forging meaningful collaborations and successful partnerships. Building on this principle, the Organiser has selected UPS Middle East FZE, a subsidiary of United Parcel Service Inc. (UPS), as the Official Logistics Partner of Expo 2020 Dubai. UPS offers a wide range of logistics services at competitive rates. Details on UPS and the services it offers to participants are provided in Chapter 11.

1.4.2 Planning

C-02 Participants must submit a general transportation plan to the Organiser through the Participant Portal at least 45 calendar days before initiating their first shipment. The plan must contain the following information:

- › Method of transportation (air, ocean, or road)
- › Description of goods
- › Quantity of goods
- › Location and details of any installation requirements (provided by the Organiser on a rate card if available within agreed service levels)
- › Scheduled delivery date for each consignment
- › Details of the participant's logistics manager including deputy logistics manager (if appointed)
- › Re-exportation plans of the goods (if applicable)
- › Incoterms

Participants must inform the Organiser, through their Country Manager, if and when they make any changes to their general transportation plan. The updated plan must be resubmitted to the Organiser.

C-03 Participants must ensure that their logistics manager or their representative is present onsite to receive and sign off their deliveries.

C-04 Participants must ensure that all equipment and resources required to unload and position their exhibits is available onsite at the time of delivery of the exhibits.

1.4.3 Marine/Goods in Transit Insurance

C-05 Participants must arrange Marine/Goods in Transit Insurance to provide coverage for loss of, damage to, or destruction of their property and goods while in transit and during loading and unloading. For further details on the Organiser's specific requirements in arranging Marine/Goods in Transit Insurance, see Chapter 3 of the Insurance Guide.

1.5 Test Events

The Organiser plans to run a series of Test Events in the lead up to the Expo event. These Test Events could take place during the construction and load-in period, and may cause temporary disruption to the day-to-day operation of the site. Participants are encouraged to take part in these Test Events to test their event time end-to-end supply chain along with their resources and processes. Further information on the type of Test Events that will be conducted, including the timeline, will be available on the Participant Portal.



2 ∴ Sustainability





A sustainable Expo 2020 Dubai embodies the principles of sustainable development, respecting ecological limits and natural resource constraints, encouraging prosperity and well-being while optimising conditions for human development. It also lays the foundation for a sustainable future for generations to come.

In line with the UAE Vision 2021 and the Dubai Integrated Energy Strategy 2030, Expo 2020 Dubai has identified a number of key focus areas that will contribute to enhance the standards for the Expo event while also providing opportunities to showcase innovations, breakthrough developments, and new solutions.

The Organiser has developed two documents, the Sustainability Policy document and the RISE™ Sustainable Operations Standards and Guidelines document, to encourage the participants to efficiently use resources, minimise carbon emissions, and reduce the impact of their site operations. These documents will help the participants to understand the standards and recommendations on sustainability, and inspire them to develop and deliver sustainable operations. The Sustainability Policy and the RISE™ Sustainable Operations Standards and Guidelines documents will be available on the Participant Portal.

2.1 Transportation of Goods

Participants are encouraged to work closely with their chosen logistics provider to achieve efficient, sustainable transportation methods using accurate and effective route planning along with consolidation of cargo.

Participants are also encouraged to calculate and offset their transportation emissions or carbon footprint. This is achieved by choosing a logistics provider that offers this service or by doing it in-house controlled by a third party.

2.2 Packaging

The Organiser will implement a waste hierarchy framework approach (Figure 2.1) for its packaging requirements, and will offer advice to participants on this strategy during the technical sessions and through the Sustainability Policy and the RISE™ Sustainable Operations Standards and Guidelines documents.

C-06 For audit purposes, participants disposing of any materials must report the type, weight, and volume of the disposed materials, the disposal process, and the end-of-life location. The Organiser reserves the right to audit the participants' supply chain to ensure that the Sustainability Policy is adhered to. For further details, see the Sustainability Policy and the RISE™ Sustainable Operations Standards and Guidelines documents.

Figure 21 Waste Hierarchy Framework



3 Transportation into the UAE and Packaging





Expo 2020 Dubai will ensure that its logistics supply chain is efficient, safe, and secure, and operates in compliance with the legislation of the UAE Federal Customs Authority.

This chapter provides guidelines on transporting goods into the UAE, handling of goods, packing/labelling/marketing of packages, and freight sanitation.

3.1 Transportation to Dubai, UAE

To ensure a seamless operation and delivery to the Expo site, the Organiser encourages the participants to use the Jebel Ali Port for ocean freight, and the Dubai International Airport (DXB) or Dubai World Central/AI Maktoum International Airport (DWC) for air freight. Alternatively, participants may also use any port (road, air, and ocean) in Dubai or any other ports in the UAE.

- C-07** Participants must ensure that the final destination specified in all of their shipping documents and cargo labels is Dubai, regardless of ports of transit in the UAE.

The Organiser recognises that effective communication is key to ensuring an efficient environment for participants' logistics and customs operations.

- C-08** For each of their consignments, participants must submit an individual shipment transportation plan to the Organiser through the Participant Portal at least 45 calendar days before the arrival of the consignment. The plan must provide the information as shown in Figure 3.1.

Figure 3.1 Contents of the Individual Shipment Transportation Plan



Participants must inform the Organiser, through their Country Manager, if and when they make any changes to their individual shipment transportation plans. The updated plans must be resubmitted to the Organiser.

If a consignment is an emergency, then this will be treated by the Organiser on a case-by-case basis by exemption only.

- C-09** If a participant's shipment includes promotional displays, brochures, advertising slides, CDs/DVDs, or other promotional gifts, such as pens, badges, and calendars, then the participant must provide a clear photograph of each item to the Organiser for submission to the relevant government entities in the UAE and for inspection prior to the goods being shipped.

The Organiser reserves the right to reject the importation of any goods that do not comply with the laws and regulations of the UAE. Further details will be provided on the Participant Portal.

G-01 Participants should instruct their logistics provider to request that the shipping line places their container on the top tier of the load, at origin, to expedite discharge at the destination.

The shipping line will then need to inform the destination port to prioritise the discharge of their container from the vessel.

3.2 Freight Forwarding, Small Package, and Courier Services

The Official Logistics Partner has a non-exclusive responsibility for the provision of global freight forwarding, small package, and courier services (air, road, and ocean) to the participants during the entire life cycle of the Expo event.

Participants are responsible for managing their own logistics requirements by utilising the services of the Official Logistics Partner or their own logistics provider, subject to the branding restrictions discussed in Section 6.5.

3.3 Operational Procedure for Transport

Throughout the course of the Expo event, access control and security management will evolve to adapt to the requirements of the site. Updates to access control and security management will be communicated to the participants through the Participant Portal.

Details on visitor hours and road restrictions during the Expo event are provided in Section 6.4.

3.4 Oversize Loads

The Organiser understands that participants may require oversize loads to enter the Expo site, hence an option in the DMS is made available to enable participants to identify loads as being oversize or abnormal. Details are provided in Section 6.2.2.

3.5 Handling of Dangerous Goods

Dangerous goods are articles or substances with hazardous properties that are capable of posing a risk to health, safety, property, or the environment when transported.

C-10 Participants must coordinate with their logistics provider to ensure that their shipments are fully compliant with the latest laws and regulations of Dubai and the UAE regarding packing and handling of dangerous goods.

C-11 The packaging for all chemicals and hazardous materials (such as flammable, toxic, pressurised canisters, or radioactive materials) must be prepared in accordance with the packing, marking, and labelling standards set out in the most recent publications of the following international transportation regulations:

- › International Maritime Dangerous Goods (IMDG) Code
- › International Air Transport Association Dangerous Goods Regulations (IATA DGR)

The IMDG Code and IATA DGR are widely published materials and are available online.

3.6 General Packaging Guidelines

Throughout the life cycle of the Expo event, packaging needs to be of the highest standard to protect goods from shock, rupture, breakage, loss, and climatic extremes that are encountered in the UAE such as extreme rainfall, salty atmosphere, extreme heat, high humidity, and fine drifting sand.

G-02 Packaging materials should be made from recycled materials and should effectively protect the goods from the moment they leave the factory, production site, or origin until they reach their final destination. The method of packaging the products should also be sufficient to protect shipped items against the hazards associated with handling, transportation, and storage across ocean, air, or road.

G-03 Before packing, all materials should be inspected internally and externally to ensure that they are free from hay, straw, or similar vegetable fibres to restrict the spread of pests, diseases, or fungi and as such, should not be used in packaging.

G-04 The nature of the goods and the degree of protection required by the goods should govern the final selection and quantity of the packing materials to be used.

G-05 Participants should use high-quality wooden cases or crates that can easily be reused and reshipped. Cases and crates should be constructed of softwood or rigid plywood, should be solid and robust, and should have ends that are screwed or nailed in a manner where no sharp pieces are exposed.

G-06 Goods should be properly secured inside cases and crates to ensure immobility during handling and transport.

- G-07** Goods that require special handling, such as fragile items or those that need to remain upright, should have a shock/tilt indicator (impact) device attached to them to detect and record any impact or movement.
- G-08** If any defects in the packaging are discovered during inspection, then participants should make the modifications at their own expense. Participants are also responsible for any subsequent shipment delays and possible costs due to these modifications.
- G-09** Packing materials should be able to tolerate exposure to high humidity levels during transportation.
- G-10** Fragile goods should be wrapped with moisture-proof paper to protect their surface and prevent adhesion to the packing material.
- C-12** Participants must remove and properly dispose of all their empty packaging not intended for reuse. In case of non-compliance, the Organiser will take necessary action at the participants' costs.

3.7 Labelling and Marking

Packages need to be clearly and properly labelled in order to minimise loss and damage, and ensure that health and safety best practices are followed.

- C-13** Packages must be labelled completely on at least two sides for correct identification and timely delivery. Labels must be written in English, be large enough to read, and use standard metric units to indicate dimensions and weight. The details on the labels must match the information provided in the shipping documents including the final destination and any transit points. A sample cargo label format is provided in Figure 3.2.
- C-14** Each package must have two copies of the packing list, placed inside a waterproof plastic document pouch and attached to the surface of the package. The packing list must be legible and must only include the items that are actually shipped.
- G-11** If the packaging is being reused, any previous information that is not relevant to the packaging, such as labelling, should be removed.

Figure 3.2 Sample Cargo Label



Goods for Expo 2020 Dubai

Name of the Logistics Provider Freight forwarder			
Country of Shipment		Participant	
Sender Name, address, and contact details of the shipper		Consignee (Receiver) Name, address, and contact details of the final receiver	
Description of Goods			
Mode of Transport			
<input type="checkbox"/> Air Freight <input type="checkbox"/> Ocean Freight <input type="checkbox"/> Road Freight			
Piece Number	Of Total Pieces	Gross Weight (kg)	Dimensions (Length x Width x Height – cm)
Additional Comments			
These goods are for the Expo 2020 in Dubai, UAE, for the purposes of the indicated participant			

- C-15** Tags or labels must be stamped or clearly marked with full shipping marks and must be attached to the package.
- G-12** All pieces should be clearly marked and numbered, including the booth and pavilion numbers, material/serial number, and part numbers, to expedite identification and assembling and/or dismantling.
- G-13** Packages containing fragile goods or goods that require special handling (such as those that need to be kept upright) should be carefully packed and clearly stencilled on all sides with the appropriate standard handling labels. See Figure 3.3.
- C-16** Packages containing hazardous, dangerous, or restricted goods must be properly marked in accordance with the relevant regulations of the UAE.















3.8 Bonded Deliveries

Customs will seal direct deliveries from ports, airports, or their warehouses to the Expo site. The participants' representatives or their logistics managers are the only personnel authorised to break the seal under Customs' supervision. If a bonded delivery arrives to the site without a seal or with a broken seal, an investigation will be conducted and the delivery may be refused entry to the site.

3.9 Freight Sanitation Guidelines

Expo 2020 Dubai is committed to protecting and preserving the environment, hence participants are encouraged to take into consideration the impact of their operations on the environment when planning their logistics activities.

Figure 3.3 Standard Package Handling Labels

Name of Label	Label	Definition
Centre of gravity		Indicates where the centre of gravity point is on the package
Clamp sides		Identifies where clamps need to be placed for handling of the package
Danger		Package contains dangerous and/or toxic material
Do not roll		Package must not be rolled
Fragile		A fragile cargo
Heavy weight this end		Indicates that the centre of gravity is on one side
Keep away from heat		Package needs to be kept away from heat
Keep away from heat and radioactivity		Package needs to be kept away from heat and radioactive exposure
Keep dry		Package requires protection from water and moisture
No trolley this side		The location in the package where trolleys or trucks must not be placed
Sling		The location in the package where a sling wire is to be applied
Stacking limits		Package must not be stacked under other packages
Temperature limits		The temperature limits between which the package needs to be kept
Top		Package must not be placed upside down
Use no hooks		Hooks must not be used to lift the package

3.9.1 Freight and Container Sanitation

G-14 Participants should ensure adequate sanitation of their freight and containers.

G-15 Participants should ensure that their individual shipment transportation plan contains adequate sanitation policies which cover the following (as a minimum):

- › Proper sanitation of equipment and freight
- › Pest control measures in the transportation units and storage facilities at the country of origin
- › Packaging materials provided by a reputable supplier

3.9.2 Wood Treatment

The International Standard for Phytosanitary Measures No. 15 (ISPM 15) is developed by the International Plant Protection Convention (IPPC) of the Food and Agriculture Organisation of the United Nations. ISPM 15 describes the phytosanitary measures that reduce the risk of introduction and spread of quarantine pests associated with the movement in international trade of wooden packaging materials made from raw wood. Currently, the only ISPM 15 approved wood treatment measures are heat treatment and methyl bromide fumigation.

C-17 Participants must ensure that all of their wooden pallets, wooden packaging materials, and any other wood materials with a thickness greater than 6 mm, and used for import, are treated in accordance with the requirements of ISPM 15 before arriving in the UAE. For detailed information on the requirements of ISPM 15 and on the exemptions from the provisions of the standard, see the link provided in Supporting Resources at the end of this document.

C-18 Wooden pallets used for export may need to be treated in accordance with the requirements of ISPM 15 depending on the type of wood or the country receiving the pallets. Participants must ensure that their wooden pallets comply with the relevant laws of the final country destination post event.

C-19 Participants must ensure that their treated wooden pallets and wooden packaging materials display a mark as shown in Figure 3.4 to indicate that the materials have been subjected to ISPM 15 approved treatment. The mark must comprise the following components:

- › The two-letter ISO country code (in place of AE in Figure 3.4)
- › The code identifying the licensed company and treatment provider (in place of XXX in Figure 3.4)
- › The code identifying the approved treatment measure applied: HT for heat treatment or MB for methyl bromide fumigation
- › The code 'DB' if wood debarking has taken place (added to the code for the approved treatment measure)
- › The trademarked IPPC logo

The mark must be permanent, non-transferable, legible, visible, and preferably displayed on at least two sides of the item which has been treated.

Figure 3.4 Example of Marking on Wooden Packaging Material

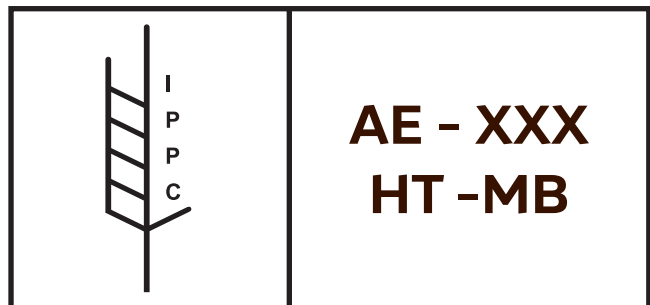



4 UAE Customs Clearance Processes





UAE Customs has permitted the participants of Expo 2020 Dubai to complete their customs clearance using the Expo 2020 Zone.

Customs clearance generally involves five steps: declaration of goods, clearance from the tax authority, customs inspection and submission of permits (if required), and completion of the Transit-In Declaration documents. Participants need to comply with these steps and adhere to the regulations of UAE Customs to ensure a seamless and timely clearance of their imported goods. Figure 4.1 provides a general overview of the customs clearance process.

Figure 4.1 Customs Clearance Process

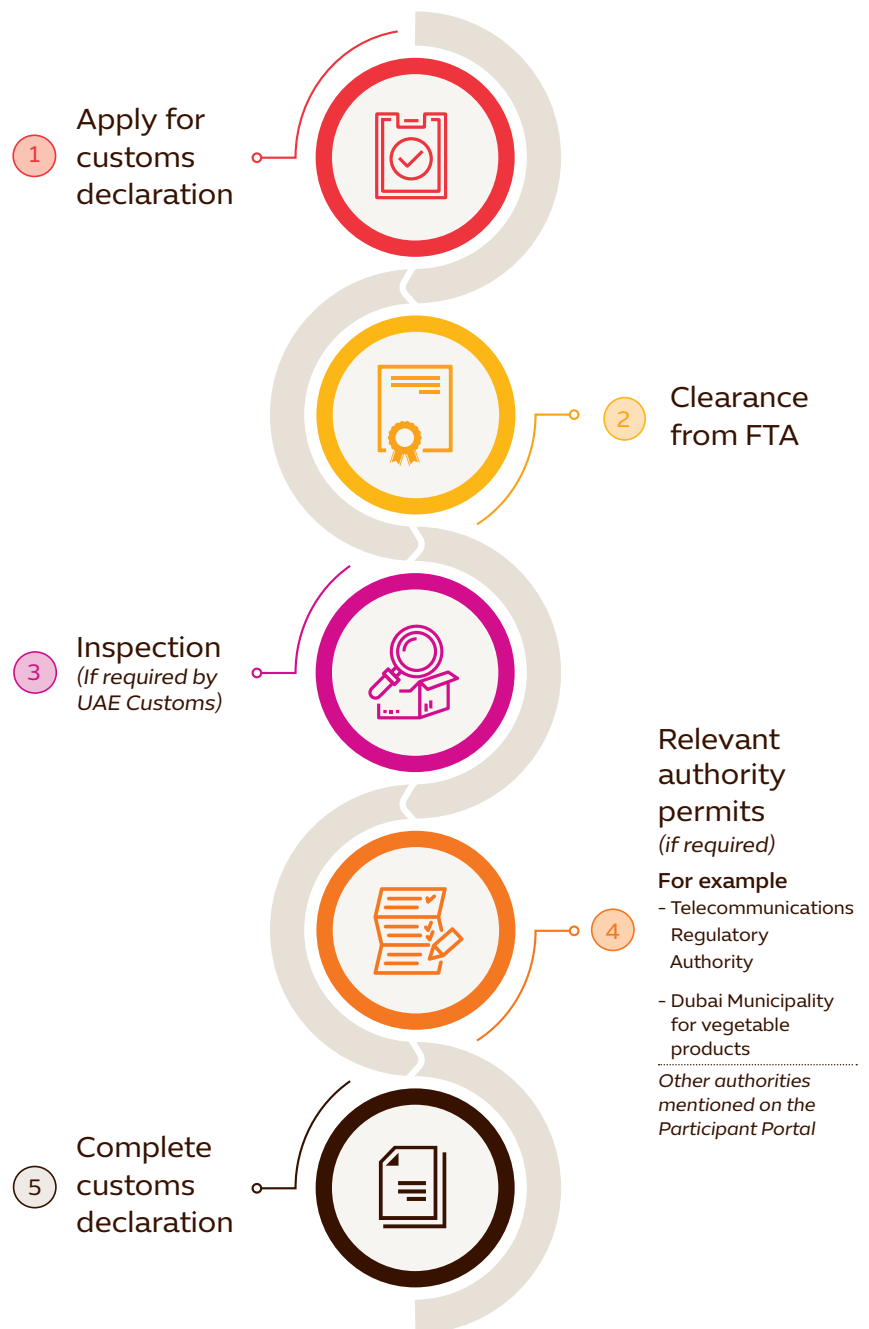

Customs clearance is expected to occur within 6 hours from receipt of all of the correctly completed shipping documents through to the release of the shipment by Customs.

Participants who wish to import goods into the Expo 2020 Zone need to meet the following criteria in order to temporarily waive payment of their customs duties:

- › Their Expo 2020 licence is valid
- › Their Customs Free Zone Bills of Transit-In are processed under their name
- › Their goods are in the Expo 2020 Zone
- › A customs inspection is conducted on their shipment (if required)

If the participants transport their goods outside the Expo 2020 Zone, then they will need to pay customs duties and taxes.

C-20 Participants must complete their declaration information at line item level and update it against the import of their goods cleared under the Expo 2020 Zone.

4.1 Customs Declaration

The customs declaration is the process wherein importers/exporters declare their goods for import/export, in detail, in accordance with Customs' procedures. The participants' logistics providers or designated customs brokers will complete the customs declaration process.

C-21 Participants must ensure that the free zone Transit-In Declaration is used to import their goods into the Expo 2020 Zone. This declaration may be processed against imports from the rest of the world, the UAE local market, or the GCC.

C-22 Participants must ensure that their shipment invoices are declared at a line item level where the commodity, country of manufacture, value, quantity, currency, and correlating harmonised code are clearly reflected.

G-16 Participants should ensure that their invoices against goods that are imported and expected to be duty exempt are declared separately.

C-23 Participants must ensure that the applicable documents listed in Figure 4.2 are attached to their Transit-In Declaration.

Customs may request the participants to translate their commercial invoice to Arabic, if needed.

Figure 4.2 Document Attachments to Transit-In Declaration

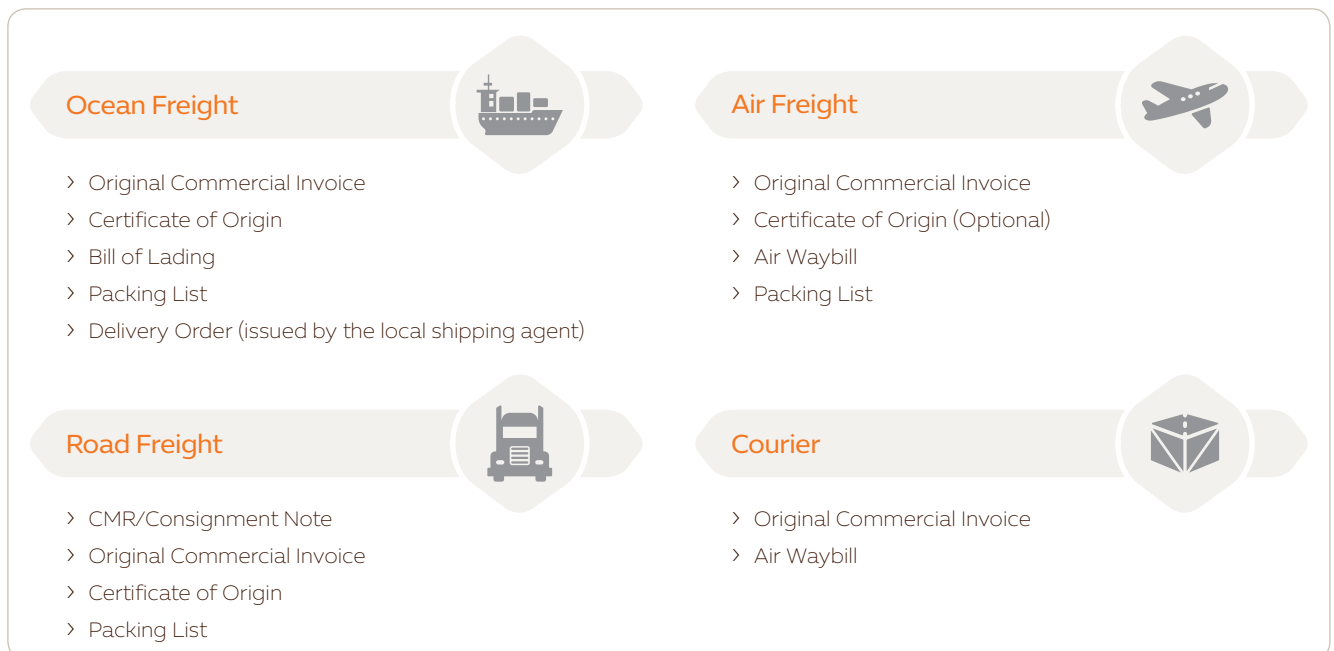

4.2 Taxes

The introduction of taxes in the UAE is part of a GCC-wide initiative to diversify the region’s economy. The UAE’s FTA is responsible for the collection and management of taxes in the country. The unique TRN provided by the Organiser to the participants will be used to communicate and perform all transactions with the FTA.

4.2.1 Value-Added Tax

Value-added tax (VAT) is a tax on the consumption or use of goods, levied at the point of sale along each step of the supply chain.

Participants will receive a refund of the VAT paid in their procurement in the UAE of the following goods to be used in construction, exhibition, and operation of the pavilion, according to the rate collected, by carrying out the necessary procedures subject to the laws and regulations:

- > Goods and services procured in direct connection with the construction, installation, alteration, decoration, and dismantlement of their exhibition space
- > Goods and services procured in direct connection with the operation of their exhibition space and any presentation within the Expo site
- > Goods and services which relate to the effective operation of the participants provided that the value of each item for which a refund claim is made exceeds the minimum amount set by the FTA
- > Goods and services imported on a temporary basis

The detailed procedures of the VAT refund will be published by the financial department of the UAE Government. The procured goods eligible for the VAT refund to be sold in the UAE following the conclusion of Expo 2020 Dubai will be subject to tax as required by the applicable laws and regulations.

The Organiser will assist the participants with the VAT refund procedures of the relevant government authorities.

4.2.1.1 VAT Import Declaration

Different VAT scenarios may apply when importing goods into the UAE, hence participants need to follow specific steps to complete the VAT Import Declaration form. To ensure the successful declaration of goods, which are subject to VAT, participants are encouraged to read the FTA’s VAT Import Declaration User Guide. See the link provided in Supporting Resources.

4.2.1.2 VAT within the Expo 2020 Zone

If goods imported into the Expo 2020 Zone, remain within the Expo 2020 Zone, and are then re-exported to a non-GCC country, those goods will not be subject to VAT. If participants sell their goods then VAT will be charged.

4.2.2 Excise Tax

Excise tax is a form of indirect tax levied on specific goods that may be harmful to health or the environment. These goods are referred to as ‘excise goods.’ Figure 4.3 shows examples of excise goods. For rates and further information on excise tax, see the link provided in Supporting Resources.

4.2.2.1 Excise Tax Import Declaration

Different excise tax scenarios may apply when importing goods into the UAE, hence participants need to follow specific steps to complete the Excise Tax Import Declaration form. To ensure the successful declaration of goods, which are subject to excise tax, participants are encouraged to read the FTA’s Excise Tax Import Declaration User Guide. See the link provided in Supporting Resources.

Figure 4.3 Excise Goods



Figure 4.4 Examples of Prohibited and Restricted Goods



Restricted Goods

- ⊕ Live animals, plants, fertilizers, and insecticides
- ⊕ Arms, ammunitions, explosives, and fireworks
- ⊕ Pharmaceutical products and medical/surgical instruments and machines
- ⊕ Print materials, publications, and media products
- ⊕ Nuclear energy-related products
- ⊕ New tyres
- ⊕ Transmitters and radio equipment
- ⊕ Alcoholic beverages
- ⊕ Foodstuffs, personal care, and cosmetic products
- ⊕ Rough diamonds



Prohibited Goods

- ⊖ All kinds of narcotic drugs
- ⊖ Goods from embargoed countries
- ⊖ Gambling tools, machinery, and other related devices
- ⊖ Nylon fishing nets
- ⊖ Used, reconditioned, and inlaid tyres
- ⊖ Radiation and nuclear fallout contaminated substances
- ⊖ Items that are offensive against Islamic faith and public morals
- ⊖ E-cigarettes and electronic hookah
- ⊖ Paan and betel leaves
- ⊖ Any other goods or items, the importation of which is prohibited under the GCC Common Customs Law or any other laws or regulations applicable in the UAE

4.3 Customs Inspections

Customs authority may conduct risk-based targeted inspections or random inspections when processing customs declarations. Shipment inspections are determined based on the goods and the information stated in the customs declaration, which needs to be completed before the shipment is released for delivery.

C-24 Participants must ensure that their logistics manager, deputy logistics manager, or representative is present during any customs inspection.

4.4 Prohibited and Restricted Goods

Prohibited goods are those that cannot be imported, exported, or transited into the country.

Restricted goods are those which are required to meet certain conditions, such as the completion of permits and payment of related fees and taxes, before clearance through Customs is obtained. Figure 4.4 lists some examples of prohibited and restricted goods.

C-25 Participants must comply with the latest laws and regulations of the UAE regarding prohibited and restricted goods.

For an updated and comprehensive list of prohibited and restricted goods, see the Participant Portal.

C-26 Participants must not import/export fake goods into/from the UAE.

4.5 Goods that are Exempt from Customs Duties

The following goods are exempt from customs duties:

- › Small samples (other than alcoholic beverages, tobacco goods, and fuels) which are representative of foreign goods displayed in the participants' exhibition space provided that:
 - They are supplied (free of charge) from abroad and used solely for distribution (free of charge) to the visitors at the participants' exhibition space, for individual use or for consumption by the visitors to whom the samples are distributed
 - They are identifiable as advertising samples and are individually of little value
 - They are not meant for commercial purposes
 - They are of sample size
 - They are food and beverage samples, which are not distributed in packs, and are consumed at the Expo site
- › Goods imported solely for demonstrations, or for demonstrating the operation of foreign machinery displayed at the participants' exhibition space, and consumed or destroyed during such demonstrations

- > Marketing and promotional materials for foreign goods displayed at the participants' exhibition space, provided that these are supplied (free of charge) from abroad and are used solely for display or distribution (free of charge) to visitors
- > Goods required by the Section staff to carry out their official duties
- > Imported consumables that are used for constructing, setting up, decorating, animating, or furnishing the participants' exhibition space
- > Imported plans, drawings, files, records, forms, or other documents that are used by the participants

4.5.1 Personal Effects

Participants may import their personal effects and used household items into the UAE for the Expo event. These goods will be duty exempt only if the following requirements are met:

- > Participants are arriving to the UAE for the first time for residence
- > Participants have proof of visa status
- > Goods are in a visibly used condition
- > Goods are not in commercial quantities (or the quantity is within the limit for furnishing a residence)
- > The owner of the declaration and of the goods is the same as is declared on the shipping documents
- > The invoice and packing list of the items are presented

If, after an inspection, the goods are deemed to be new or in commercial quantities, then applicable duties and taxes will be applied.

Participants who wish to import a vehicle into the UAE are encouraged to check for the right import procedure on the website of Dubai Customs, which is provided in Supporting Resources.

4.6 Completion of Customs Declaration

Declaration fees are paid by either the participants or their logistics provider, whoever submits the customs declaration for commercial goods. The different types of declaration fees are detailed on the website of Dubai Customs.

4.6.1 Customs Duties

C-27 Participants and their logistics provider must comply with the obligations related to the payment of customs duties for commercial goods.

Except for tobacco and alcohol, customs duties for all other commercial goods are calculated at 5% of the total CIF value (cost, insurance, and freight). Tobacco is calculated at 100% of its value or collectible rate, whichever is higher, while alcohol is calculated at 50% of its value.

4.6.2 Submission of Physical Documents

C-28 In accordance with Customs Notice No. 1/2018 (see Supporting Resources), participants must ensure that they submit their declared supporting physical documents to a designated customs centre (see Figure 4.5) within 14 calendar days of customs clearance. Failure to submit the physical documents within the stipulated time may lead to penalties.

To view the updated and comprehensive list of customs centres for document submission, see the Participant Portal.



Figure 4.5 Customs Centres for Document Submission



5 : Warehousing





Warehousing options are available to participants either through the Official Logistics Partner or their own logistics provider.

Participants have the freedom to use their own preferred warehouse to store their goods.

The Official Logistics Partner is able to offer warehousing services to participants' pavilions, with the exception of food and beverages. All of these services are charged on a rate card basis which can be accessed through the Participant Portal. Details on the storage options offered by the Organiser and the Official Logistics Partner, including the warehouse locations and hours of operation, will be available on the Participant Portal.

Participants need to arrange an appropriate Property Insurance to provide coverage for loss, damage, or theft of their goods. Further information is provided in Chapter 4 of the Insurance Guide.

Participants need to adhere to the correct customs rules and regulations.

5.1 Operational Procedure

C-29 Subject to availability, participants who wish to utilise the Official Logistics Partner's warehousing services must inform the Official Logistics Partner at least 90 calendar days in advance of the arrival of their goods. All warehousing services, including storage, retrieval, and special services, such as repacking or light assembly, are available on a rate card basis. All forms and templates required are provided on the Participant Portal.

If there is an emergency storage requirement, then this will be treated by the Official Logistics Partner on a case-by-case basis by exemption only. The Official Logistics Partner may apply premium charges outside the rate card.

If the participants' goods are delivered to the Official Logistics Partner's warehouses, then at the point of delivery, the Official Logistics Partner will carry out the following activities as part of the rate card service:

- › Inspect all packaging for obvious damages
- › Where appropriate, check quantities on arrival to ensure conformity with documentation and/or expectation
- › Verify that all paperwork regarding customs clearance, health, and pest control is present and correct
- › Confirm that any tamper-evident seals on the packaging are intact

Further details on the process and specifications for screening the participants' goods on arrival at the Organiser's warehouses is provided on the Participant Portal.

The Official Logistics Partner also offers special handling services for valuables, which will be undertaken in accordance with the regulations of the relevant authority. For further information on special handling services, see the Participant Portal.

5.1.1 Warehouse Operations

C-30 Participants must submit an Advance Shipping Notice (ASN) or an Inbound Advice Notification to the Official Logistics Partner through the Participant Portal for all of their inbound deliveries. The notice must contain the following information:

- › Terms, carrier's name, waybill number, and carrier's expected time of arrival
- › Stock keeping unit (SKU) list including description and quantity expected
- › Hazardous material (HazMat) code, if applicable

Further information, including the relevant forms, will be available on the Participant Portal.

Once the participants' goods arrive at the Official Logistics Partner's warehouses, the Official Logistics Partner will carry out the following activities:

- › Perform a delivery vehicle verification check
- › Check for damage, match the goods against the ASN or any inbound documentation, record any variance, and report it to the concerned participant
- › Agree on a discrepancy process with the participant, as required, to resolve any variances
- › Put the goods in the warehouse
- › Provide a receiving report detailing:
 - ASN reference numbers
 - SKU and quantity received
 - Receipt date and time
 - Warehouse location
 - Carrier's name and waybill number

Goods at the warehouse will be stored in an appropriate environment (temperature-controlled or ambient conditions).

The Official Logistics Partner is able to provide a high-value security service, if required. For further details, see the Participant Portal.

Participants who utilise the Official Logistics Partner's warehousing services may choose from the multiple service level options that are available via a rate card. Further information on these levels of service will be available on the Participant Portal.

Additional preparation services for outbound shipments, including wrapping, sealing, labelling, and reworking, are available for the participants on a rate card basis. Shipments comprising multiple SKU lines will be over boxed or palletised with appropriate identification labels on the exterior.

The maximum dimensions and the weight of pallets is dependent on the warehouse configuration. The typical size and weight restrictions on pallets are provided in Figure 5.1.

Figure 5.1 Size and Weight Restrictions on Pallets

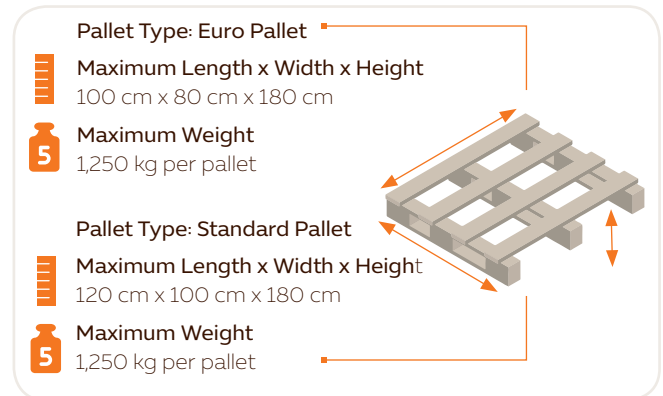

5.1.2 Inventory and Stock Counts

If the participants choose the Official Logistics Partner for their warehousing requirements, the Official Logistics Partner will provide them with a weekly inventory snapshot (in soft copy) summarising their specific inventory. Participants may arrange periodic stock counts or other inventory inspections directly with the Organiser on a rate card basis.

C-31 Initial access to the Official Logistics Partner's warehouses will be granted on a pre-arranged and accompanied basis only. In this case, participants must submit an access request to the Organiser through the Participant Portal at least 90 calendar days in advance of their intended access to the warehouse. Further details will be provided on the Participant Portal.

5.2 Storage of Packaging Materials

Participants may store their packaging materials, such as flight cases and wooden crates, at the Official Logistics Partner's warehouses on a rate card basis.

Participants who require long-term storage for their containers are encouraged to directly engage with the Official Logistics Partner or their own logistics provider.

6 ∴ Final Stage of Delivery





Detailed delivery planning is essential especially during the pre-event and post-event phases when various activities simultaneously take place across the Expo site. Participants need to ensure that their deliveries and other logistics operations are effectively and efficiently planned.

This chapter provides guidelines to participants as to the protocols and restrictions that will apply for deliveries to their pavilion/plot and, where appropriate, collections from their pavilion/plot before, during, and after the Expo event.

6.1 Site Security

Participants' goods and materials will need to be screened, pre-checked, and sealed before entering the Expo site to ensure that their deliveries do not contain prohibited goods. Goods will need to be screened at the RSA and checked at a VSA on the Expo site perimeter. Figure 6.1 illustrates the Delivery Access Protocols for site deliveries.

Figure 6.1 Delivery Access Protocols

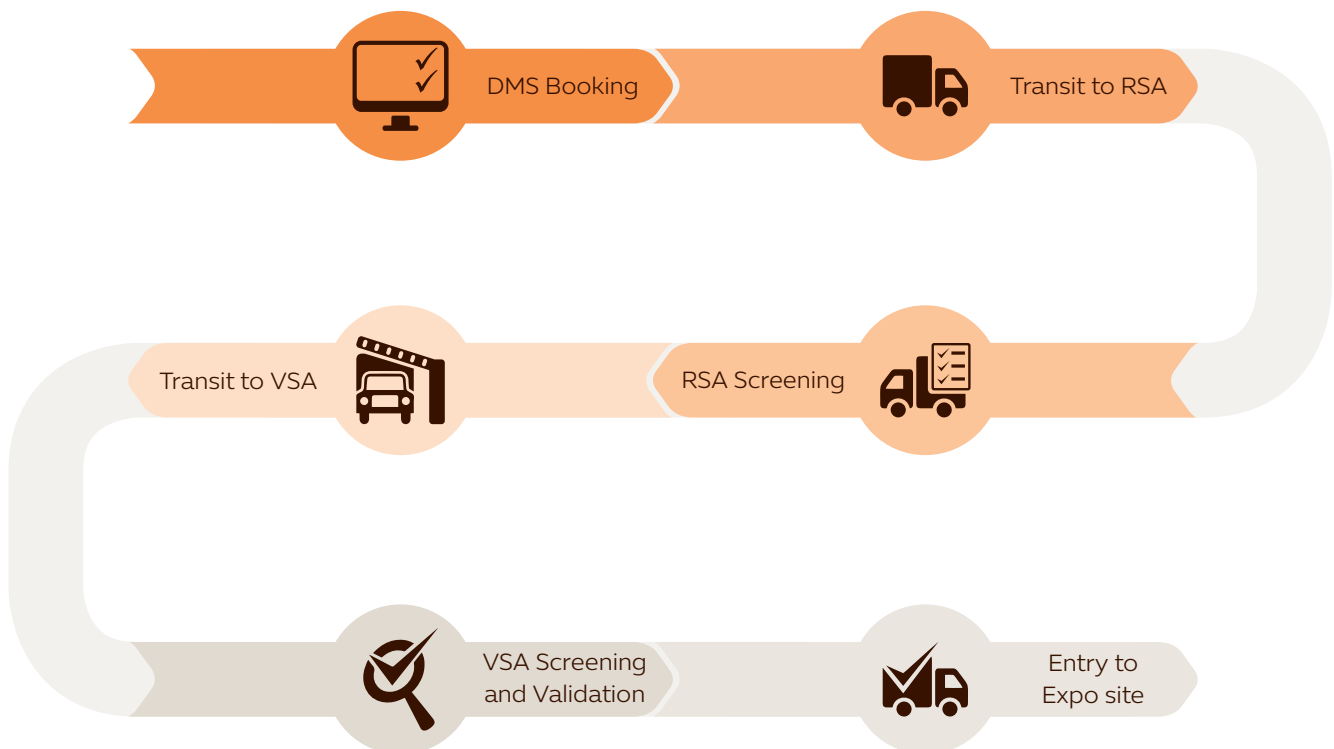

- C-32** Participants must ensure that their delivery vehicles comply with the security screening procedures prior to entering the Expo site during the event. Participants must also comply with the restrictions on vehicle size across the site.
- C-33** The road network across the Expo site includes a number of thoroughfares with vehicle size restrictions. Where possible, participants must use 20-ft rather than 40-ft shipping containers to maintain ease of access, ingress, and egress.
- G-17** The security screening levels and Delivery Access Protocols at the RSA and VSAs will evolve over time. Security will validate the authorised accreditation of the vehicle and driver as well as the vehicle material permit. Participants should coordinate with the Organiser and check the Participant Portal regarding any updates on the security screening procedures and the Delivery Access Protocols.

Figure 6.2 shows the approximate locations of the RSA and VSAs on the Expo site.

6.1.1 Site-Wide Lockdown

Lockdown is the stage during which a phased security sweep will take place. After which, all access control measures will come into effect during the event. Further information on lockdown is available on the Participant Portal.

6.2 Booking on DMS

The Organiser has deployed an online DMS to book vehicles arriving at the Expo site in order to regulate traffic flow and minimise congestion around and inside the site. The DMS is accessed via the Participant Portal. Innumerable users have access to the DMS. Those users need to be defined as schedulers who are responsible for making the delivery bookings.

- C-34** Participants must ensure that all their deliveries, and those of their vendors and stakeholders, are pre-booked on the DMS at least 48 hours in advance of their planned delivery. Each booking must have an arrival time (from a drop-down list of available timeslots) along with vehicle licence plate number and driver's name. The Organiser reserves the right to refuse the entry of vehicles without DMS booking.

Figure 6.2 Location of RSA and VSAs on the Expo Site

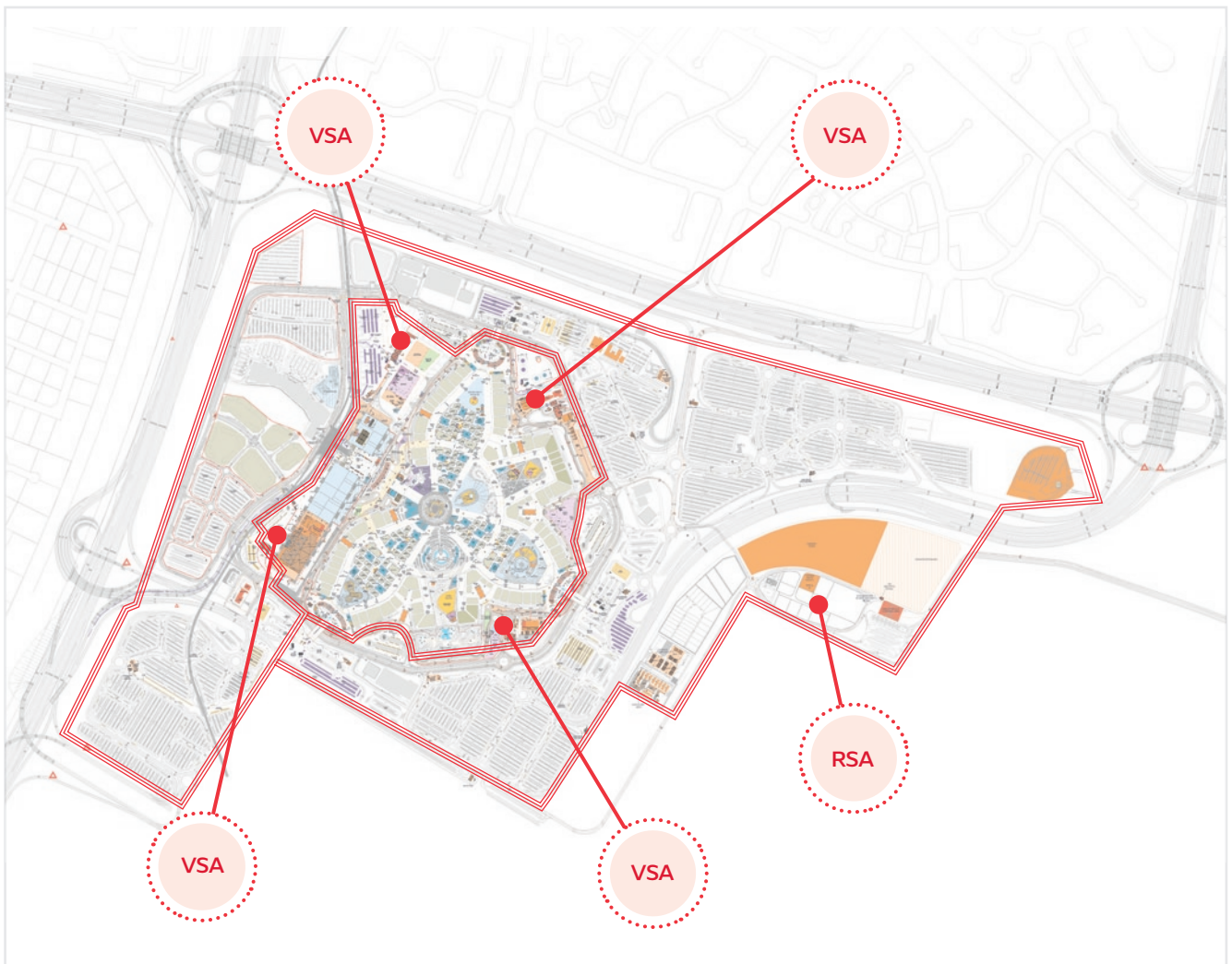

In order to deliver a notable visitor experience and maintain safety site-wide, a set number of delivery slots will be available during visiting hours.

C-35 Participants must nominate DMS users who will be issued with login credentials. Participants are urged to ensure that these credentials are not shared across their users as this will impair the integrity of the system and its data.

To help the DMS users understand the system and the booking process, frequently asked questions and training on how to create and manage DMS bookings will be available on the Participant Portal.

6.2.1 Vehicle Size Restrictions Onsite

The only permissible trailers on site are those of a maximum length of 33 ft (10.06 m) and therefore, shipping containers that are to be directly delivered to participants’ pavilions are restricted to a maximum size of 20 ft (6.10 m).

6.2.2 Oversize or Abnormal Loads

The DMS has an option to enable participants to identify loads as being abnormal or oversize which would require marshalling support. The Organiser will monitor these deliveries through the DMS.

C-36 Participants who wish to deliver an oversize or abnormal load to the Expo site must first obtain the Organiser’s approval. Once the approval has been given, participants must contact the DMS team ahead of time to ensure that proper arrangements are in place before the arrival of the load. Participants must also coordinate with the Organiser regarding the approved routes through the site.

C-37 For exhibits that are heavy and oversized or that require special loading and positioning, participants must ensure that their logistics manager arrives at the Expo site beforehand, provides a detailed layout diagram, and

supervises the loading and positioning of the exhibits. In case of absence of the logistics manager, the Organiser may arrange the positioning of the exhibits according to the layout diagram provided by the participant and at the latter’s expense and liability.

6.3 Accreditation

C-38 Participants must ensure that their personnel carry valid accreditation in order to access the Expo site. Details of the accreditation process will be provided in the Accreditation Guide and on the Participant Portal. If the participants’ personnel are arriving with a delivery vehicle, then the Delivery Access Protocols for personnel and the vehicle must be followed.

6.4 Visitor Hours

The Expo event will run from 20 October 2020 to 10 April 2021. Figure 6.3 shows the visitor hours during the Expo event.

Visitor hours during special days will be published on the Participant Portal.

C-39 Participants must comply with the laws and regulations of Dubai regarding restrictions on the movement of commercial vehicles. The visitor hours, identified in Figure 6.3, depict the time when gates will be open and closed for visitors. Delivery slots will be built around these hours and further details will be published on the Participant Portal.

G-18 Participants should check with their logistics provider as to how the road restrictions will affect their deliveries. Restrictions may be based on the size of the vehicle or the time of operation. Further information will be available on the Participant Portal.

Figure 6.3 Visitor Hours

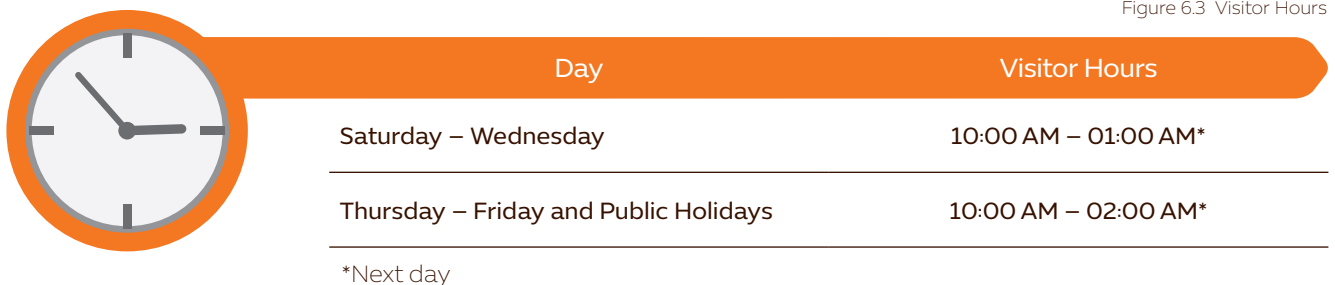

G-19 The Islamic month of Ramadan in the year 2021 is expected to occur between 12 April and 11 May. Participants should take the reduced working hours during Ramadan period into consideration when planning their logistics and customs operation after the conclusion of the Expo event.

6.5 Branding Restrictions

C-40 Participants who wish to use an alternative logistics provider for their final stage of deliveries to the Expo site must ensure that their provider complies with the Organiser’s branding restrictions (see Figure 6.4). Compliance on branding will be checked at the RSA. The Organiser reserves the right to refuse the entry of vehicles that do not comply with the branding restrictions.

6.6 Receiving of Goods

Where participants utilise the Official Logistics Partner’s warehouses, then the Official Logistics Partner may provide deliveries to pavilions. Details on the services available, service levels, and rate cards are available on the Participant Portal.

Tariffs for longer lead-times and/or collections from the warehouses of the alternative logistics providers will be available on the Participant Portal.

C-41 Participants must take responsibility for unloading their goods from delivery vehicles to their pavilions or sectors, and for positioning these goods inside their pavilions or to their assigned spaces.

C-42 Participants must ensure that their logistics manager, deputy logistics manager, or representative is present during unloading. The responsible staff must sign the delivery note to confirm that the goods have been delivered and that they correspond to the order. Participants must promptly move their goods into the pavilion or to their assigned spaces. In case of absence of the logistics manager, deputy logistics manager, or representative, the Organiser will arrange for the goods to be temporarily warehoused at the expense and liability of the participants, on a rate card basis.

Details of vehicle and parking restrictions, unloading protocols, and other relevant restrictions that apply to particular areas will be available on the Participant Portal.

Figure 6.4 Branding Restrictions

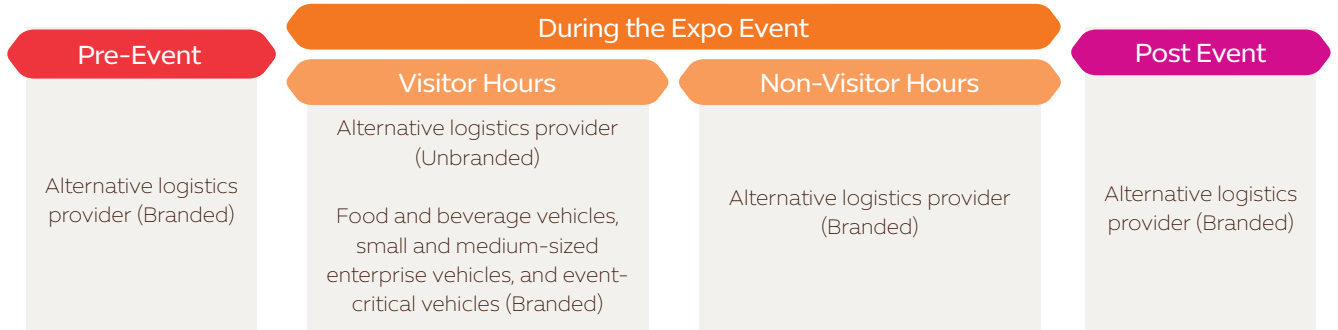



7 ∴ Reconciliation and Audit



Goods that are imported into or exported out of the Expo 2020 Zone are required to be recorded in a goods inventory system. The inventory needs to be reconciled periodically as Customs may conduct random audits to ensure compliance with the relevant regulations.

This chapter details the goods inventory and reconciliation process as well as the customs audit requirements that participants need to comply with.

Figure 7.1 shows a recommended record-keeping and reconciliation process that is in line with Customs' audit requirements. Participants may complete this whole process by themselves without using the logistics provider.

Figure 7.1 Record-Keeping and Reconciliation

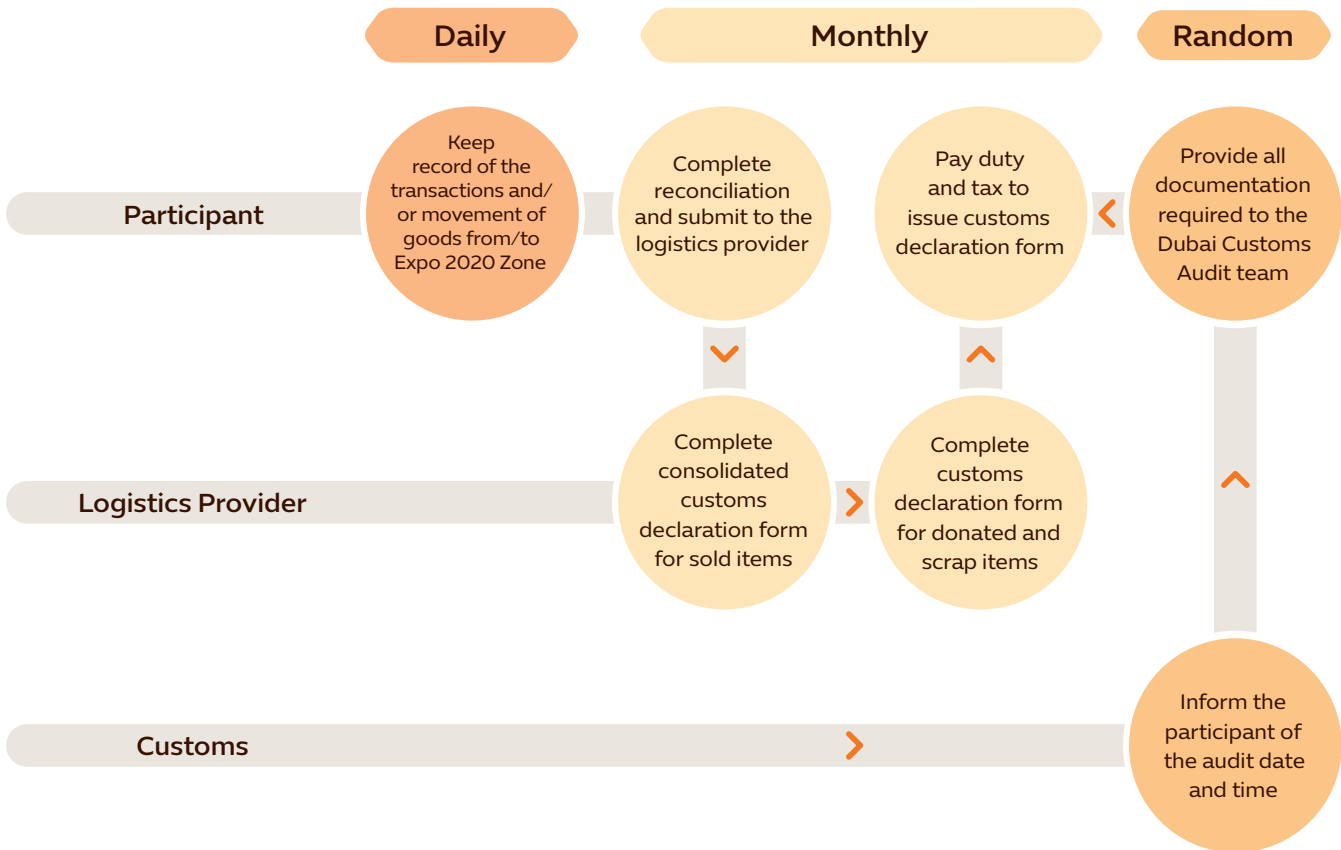

7.1 Goods Inventory and Reconciliation

C-43 Participants must record all goods that they have imported and declared under the free zone Transit-In Declaration in their own goods inventory tracking system. At the time of export, participants must update the free zone Transit-Out Declaration information in their goods inventory system. The inbound and outbound goods inventory must match during the monthly reconciliation and during the final reconciliation at the end of the Expo event. Participants must submit a monthly audit report based on the monthly reconciliation to Customs' Audit Authority.

C-44 Participants must ensure that the free zone Transit-Out Declaration follows the customs claim submission process after the export of the shipment. This is a mandatory requirement that supports the inventory reconciliation with Customs. Failure to comply with this process may lead to penalties.

7.1.1 Commercial Goods Reconciliation

C-45 Participants or their representatives must issue the necessary commercial invoices when finalising commercial transactions, and keep a record of all sales where the commodity, country of manufacture, value, quantity, currency, and correlating harmonised code are clearly reflected.

C-46 Participants or their representatives must keep sales invoices, purchase orders, and commercial invoices until the decommissioning process is complete. This is subject to Dubai Customs issuing a non-liability certificate.

Any breach of the provisions pertaining to these procedures will be regarded as non-compliance and may result in penalties and/or cancellation of Customs' services that are stipulated in this Logistics and Customs Guide and the GCC Common Customs Law.

7.2 Customs Audit

The audit process reconciles imports, exports, and inventory balances at a line item level against the participants' inventory.

Dubai Customs performs scheduled and random audit inspections, and requires the participants to provide the necessary information in a timely manner.

C-47 Participants must comply with the audit requirements in accordance with the applicable audit procedures.

All customs audits will be scheduled and random audits will take place with 7 working days' notice.

8 ∴ Decommissioning and Load Out





Decommissioning is the removal of the contents of a pavilion and any relevant construction materials after the conclusion of the Expo event. Load out is the physical movement of inventory out of the Expo site to its final destination after the event.

This chapter details the process of removal and dispatch of goods from the UAE and the Expo 2020 Zone.

- C-48** Participants must obtain an exit permit from the Organiser prior to removing their goods from the Expo site.
- C-49** Participants must obtain a non-liability certificate from the Audit Department of Dubai Customs to complete the decommissioning process. The non-liability certificate is issued once Dubai Customs has confirmed that the reconciliation of goods imported against exports, sales, giveaways, and gifts has occurred.
- C-50** If goods are lost, damaged, scrapped, or donated, then participants must submit the relevant documentation to Dubai Customs to reconcile the inventory.

Participants are responsible for all goods that cannot be reconciled as well as any charges and/or penalties that may be imposed by Dubai Customs.

- C-51** Participants, subcontractors, and other functions must not leave unwanted assets on the Expo site after the conclusion of the Expo event. Any such assets left behind will be forwarded to the owner at their own cost.

8.1 Planning of Load Out of Goods

The Organiser will set up and run technical sessions that include the decommissioning process. These sessions will focus on ensuring that the participants understand the logistics and customs clearance processes required during load out.

- C-52** Participants must submit a load out plan to the Organiser through the Participant Portal at least 90 calendar days in advance of their planned load out activities.
- C-53** All vehicles exiting the Expo site will pass through a VSA. As such, participants must ensure that their vehicles comply with the exit protocols. Details on the exit protocols will be available on the Participant Portal.
- C-54** Participants may request logistics support from the Official Logistics Partner (on a rate card basis through the Participant Portal) through to 30 April 2021, after which they must directly engage with any logistics provider.

Similar to the inbound process, participants have multiple route options with the outbound logistics process:

- › Direct to port of exit
- › Via the Official Logistics Partner's warehouses (at the participants' cost)
- › Via the warehouses of the participants' logistics providers

8.2 Consolidated Declaration

C-55 Participants or their representatives must submit a monthly online declaration for their giveaways, gifts, and the retail sale or consumption of their goods. Customs duties, tariffs, and taxes will be applicable to these goods unless they are exempt. Further details will be available on the Participant Portal.

8.3 Scrap and Recycling

The Organiser encourages the participants to reuse, re-export, or relocate most of their assets before recycling or scrapping them. The provision of a site-wide waste management contractor after the Expo event is yet to be confirmed. Updates will be communicated on the Participant Portal.

- G-20** Participants should work with a waste management contractor to develop a plan aligned with the site-wide waste decommissioning strategy.
- C-56** Participants who wish to recycle their goods must ensure that the value of the goods is determined by the Customs' Valuation Department. Duties may be applicable depending on the valuation.

C-57 Participants or their logistics providers must obtain the official certificate or receipt from their waste management contractor as proof of goods scrapped or recycled, and submit this to Customs during the audit or while processing their non-liability certificate. Participants must update their inventory system and keep all supporting documentation for audit purposes.





8.4 Export

Goods that are exported from the Expo 2020 Zone to the rest of the world will be processed against deposits. These deposits are refunded once the participants or their logistics providers submit their proof of export documents to Customs. The process to refund deposits is detailed in Section 8.4.1. The timelines for submission and refund of deposits will vary as they are dependent on the location of the customs centres and the journey and final destination of the inventory.

C-58 If goods are exported from the Expo 2020 Zone via a courier, then the participants or their logistics providers must submit a proof of export. Failure to submit the proof of export will prompt Customs to charge a penalty of 10% of the value of the goods.

C-59 Participants who wish to export their goods must submit the applicable documents listed in Figure 8.1.

Figure 8.1 Document Requirements for Export of Goods

			
Ocean Freight	Air Freight	Road Freight	Courier
<ul style="list-style-type: none"> › Original Commercial Invoice › Delivery Advice with the Transit-In Free Zone Declaration Reference › Bill of Lading › Packing List › Exit Certificate 	<ul style="list-style-type: none"> › Original Commercial Invoice › Delivery Advice with the Transit-In Free Zone Declaration Reference › Air Waybill › Packing List › Exit Certificate 	<ul style="list-style-type: none"> › CMR/Consignment Note › Original Commercial Invoice › Delivery Advice with the Transit-In Free Zone Declaration Reference › Packing List › Manifest 	<ul style="list-style-type: none"> › Original Commercial Invoice › Delivery Advice with the Transit-In Free Zone Declaration Reference › Air Waybill › Manifest

- C-60** Participants or their logistics provider must check and confirm the final destination customs clearance document requirement.
- C-61** Participants who wish to export restricted goods must ensure that the required permits are obtained from relevant authorities and submitted to Customs. For further information on restricted goods, see the link provided in Supporting Resources.
- C-62** Participants who intend to re-export their goods must ensure that re-export is completed within the 6-month period after the conclusion of the Expo event.
- G-21** If Customs requires an inspection on a shipment for export, participants should ensure that a time slot is booked in advance of the date of inspection. Booking may be done through the Participant Portal. Fees are not applicable if the inspection is requested by Customs.

8.4.1 Deposit Refund

- C-63** Participants who wish to refund their deposit must arrange a customs inspection and submit the relevant documents listed in Figure 8.2 to Customs to prove that the re-exportation of their goods has taken place.

8.5 Reselling

- C-64** If goods are sold, participants or their logistics provider must follow the import customs declaration process, where duties and taxes will be applicable.

Participants must update their inventory system and keep all supporting documentation for audit purposes. See Section 4.6.1 for customs duties applied on commercial goods.

8.6 Donation

- C-65** Participants who wish to donate goods to a charitable organisation must ensure that the organisation has processed the applicable Import Customs Declaration naming the participant as the donating party. This will help to ensure that the participants' inventory records are updated and reconciled with Customs' records.

Any donations not recorded in the Customs system via a declaration may lead to penalties from Dubai Customs and may delay the reconciliation process. Further details on donated goods will be published on the Participant Portal.

8.7 Giveaways and Gifts

- C-66** Participants must ensure that their inventory accounts for all the goods that they have distributed as giveaways and gifts during the Expo event. These giveaways and gifts must be declared to Customs as part of the monthly consolidated declaration. Any remaining goods for giveaways and gifts must be declared during the decommissioning phase.

8.8 Documentation Closure

- C-67** Participants must ensure that all documentation related to customs and federal tax processes is completed and submitted to relevant authorities prior to exiting the UAE.

Figure 8.2 Requirements to Refund Deposit





9 Courier Import and Export





Imports and exports through courier are becoming increasingly common and governed by courier import and export regulations. The courier consignments are cleared through a fast track basis on observance of simple formalities by courier companies.

This chapter provides guidelines for the movement of courier consignments into and out of the Expo 2020 Zone. Participants are encouraged to check with their courier agent for any updates on the guidelines for courier import and export.

9.1 Courier Import

Courier consignments that are imported and stored in the Expo 2020 Zone will not be subject to taxes and customs duties, however, specific documents need to be processed depending on their invoice value.

- C-68** Participants who wish to import courier consignments with an invoice value of up to AED 1,000 into the Expo 2020 Zone must process a low-value courier Transit-In Declaration. This declaration must be filed with a Courier Waybill as the proof of goods receipt along with the invoice and other related documentation received with the consignment. Participants must maintain these records to support the inventory and reconciliation of their goods.
- C-69** Participants who wish to import courier consignments with an invoice value greater than AED 1,000 into the Expo 2020 Zone must process a Transit-In Declaration at their own cost. Participants must maintain this document to support the inventory and reconciliation of their goods.

9.2 Courier Export

- C-70** Participants who wish to export courier consignments from the Expo 2020 Zone must process a low-value courier Transit-Out Declaration or a normal Transit-Out Declaration (whichever is applicable) at their own cost. Participants must maintain the Transit-Out Declaration and shipping documents to support the inventory and reconciliation of their goods.



A blue-tinted photograph of an airport tarmac, viewed through a window with a grid pattern. The tarmac features a series of black arrow markers pointing forward. In the background, there are airport buildings and a clear sky. A large, irregular yellow circle is overlaid on the top left, containing the text '10 : Passenger Import and Export'.

10 : Passenger
Import and
Export



Participants who wish to carry goods by hand into the UAE are required to comply with the relevant laws and regulations of the country.

This chapter provides guidelines to the participants on the import/export of personal belongings into/from the Expo 2020 Zone.

10.1 Permitted and Duty-Exempt Goods

The following passenger goods are exempt from customs duties:

- › Personal belongings
- › Gifts not exceeding AED 3,000 in total value
- › Cigarettes not exceeding 400 units
- › Cigars not exceeding 50 units
- › Minced, pressed, or mild tasting tobacco, including tumbak (pure tobacco) or water pipe tobacco, not exceeding 500 g
- › Alcoholic beverages not exceeding 4 L
- › Beers not exceeding two cartons of 24 cans each, and with a volume of not more than 355 mL each can

Duties on excess quantities will be collected, otherwise Customs will confiscate the goods.

C-71 Passengers arriving to the UAE must disclose all cash, traveller's cheques, jewellery, and precious metals in their possession that exceed the total value permitted by Customs. Passengers must complete the disclosure form available at the Customs office in all UAE ports.

For an updated list of permitted and duty-exempt passenger goods, including the allowed quantities and value, see the website of Dubai Customs.

10.2 Import

C-72 Passengers must pay duties and taxes for goods that exceed the personal allowance in quantity and value. If customs duties and taxes are not paid, the goods will be withheld for a maximum period of 30 calendar days from the arrival date, after which the goods will be permanently confiscated. Passengers may request a 30-calendar day extension, subject to Customs' approval.

10.3 Temporary Import

C-73 Passengers who wish to carry goods or equipment into the UAE for exhibition or trade purposes must:

- › Declare the goods or equipment upon arrival
- › Submit the following documents to Customs upon arrival:
 - Original invoice
 - Packing list
 - Certificate of origin
 - Photographs of items (especially for jewellery and designer clothing)
 - Official confirmation letter of participation from the Organiser
- › Deposit an amount equivalent to the customs duty value of the goods or equipment (payable to the relevant customs centre)

Customs will process a Temporary Admission Customs Bill for these passengers.

10.4 Export after Temporary Import

Prior to their departure, passengers need to submit their Temporary Admission Customs Bill to Customs to refund their deposit. Customs will then conduct an inspection of the passengers' goods or equipment. The deposit will be refunded to passengers on satisfactory completion of the inspection and processing of the applicable Export Customs Declaration. The refunded amount will be equal to the value of the goods presented at the time the deposit is claimed, minus applicable fees. Passengers are advised to plan additional journey time to complete this refund process.

10.5 ATA Carnet

ATA Carnet is an international customs and temporary import-export document that is issued by the Chamber of Commerce at the country of origin of the goods. Carnets are also known as 'merchandise passports' or 'passports for goods.'

ATA Carnet is used to clear customs in multiple countries and territories without paying VAT, duties, and import taxes on goods that will be re-exported within the validity of the Carnet, or the timeline permitted by Customs, whichever is less. Goods may only be imported into the UAE under ATA Carnet within a period of 6 months from the date of temporary importation entry. This period may be extended in accordance with Customs Policy No. 38/2011. For further information on ATA Carnet, see the link provided in Supporting Resources.

10.5.1 What Merchandise is Covered by Carnets?

All types of goods and equipment may be transported under the ATA Carnet. For a detailed list of merchandise covered by Carnets, see the link provided in Supporting Resources.

10.5.2 What Merchandise is not Covered by Carnets?

Consumable goods, perishable and agricultural products (such as food, seeds, fertilisers, and pesticides), explosives, disposables, and postal traffic cannot travel under an ATA Carnet.

10.5.3 UAE Special Rules and Regulations for Carnets

Goods to be used for trade fairs, exhibitions, road shows, meetings, or other similar events are allowed to enter the UAE.

ATA Carnets are accepted for transit and for unaccompanied goods. Partial or split shipments are not accepted under ATA Carnet.

C-74 The UAE typically restricts Carnet duration to 6 months. Participants who wish to extend the duration of their Carnet must contact the UAE Customs before the 'Final Date of Re-exportation' to ensure compliance with the laws of the UAE.

The UAE Customs may charge a fee or penalty for the following violations:

- › Carnets are not presented to the UAE Customs for validation upon re-exportation
- › Failure to notify Customs, in writing, of the conversion of a Carnet entry into an import mode
- › False declaration of the value of the goods (may lead to seizure or confiscation of the goods, or prosecution)

Penalties, which may amount to a maximum of three times the value of the goods (where applicable), will also be payable.

C-75 Customs will conduct an inspection on the exit of the goods under Carnet to check if any items have been sold prior to re-exportation. Carnet holders must pay the applicable taxes and customs duties on any sold items.

C-76 The UAE accepts Replacement Carnets. If a Carnet is lost, participants must replace the Carnet by the concerned authority at the country of origin.

10.5.4 Requirements of ATA Carnet for Temporary Import or Export

C-77 Participants holding ATA Carnets for temporary import or export must comply with the following:

- › The ATA Carnet must identify the UAE in the country list of the document.
- › An itemised description of goods, permanently marked serial numbers, number of pieces, weight, and country of origin must be included in all documents.
- › The original commercial invoice must be attached along with the ATA Carnet.
- › The goods must match the details in the ATA Carnet. If, upon customs inspection, they do not match, then customs duties will be applicable in addition to customs penalties for the violation in accordance with the GCC Common Customs Law.
- › The full shipment must be re-exported after the Expo event. The UAE does not allow partial or split shipments, hence any shipment that entered the country must be re-exported in its entirety.
- › The return destination of the goods must be mentioned in the ATA Carnet.



11 :: UPS: The
Official
Logistics
Partner





The Organiser has selected UPS Middle East FZE, a subsidiary of United Parcel Service Inc. (UPS), as the Official Logistics Partner of Expo 2020 Dubai.

UPS was founded in 1907 as a private messenger and delivery service in Seattle, Washington, USA. It is the world’s largest package and freight delivery company, and a premier provider of global supply chain management solutions. UPS delivers packages and freight each business day for 1.6 million shipping customers to 8.9 million receivers (consignees) in over 220 countries and territories around the world. In 2017, UPS delivered an average of 20 million pieces per day worldwide, or a total of 5.1 billion packages per annum utilising more than 454,000 employees globally. See Figure 11.1.



Figure 11.1 UPS Profile



Artwork Source: UPS

11.1 UPS' Global Logistics Services

As a global leader in logistics, UPS promises to offer value for the participants through solutions that lower costs, improve services, and provide highly customisable supply chain control and visibility. Figure 11.2 captures the services offered by UPS to participants through its integrated road, air, and ocean global network.

Figure 11.2 UPS' Global Logistics Services



UPS has committed the capacity and capability to cater to the participants' logistics requirements from pre-event through to post-event, on a rate card basis. For further details on the rate card and the services offered by UPS globally, see the Participant Portal.

11.1.1 Freight Forwarding, Small Package, and Courier Services

Participants using UPS will benefit from its global integrated network and proven reliability and value. UPS offers less-than-container load, full container load, or oversize cargo services, connecting the dots between carriers, ports, customs, vendors, and trucking providers.

UPS also offers guaranteed time-definite and day-definite small package/courier delivery worldwide, with full tracking solutions (through Quantum View and Flex Global View) that provide an integrated view of the entire supply chain.

11.2 Advantage of Engaging with UPS

UPS aims to provide a seamless journey to participants through end-to-end logistics support. UPS is embedded within the Organiser's operations structure to optimise communication, collaboration, and interaction with each other and with the participants. This will reduce the risk for each participant.

In order to provide ease-of-use for each participant, a local UPS Account Manager, specifically trained on the logistics of Expo 2020 Dubai, will meet with participants to discuss how best the UPS services enables the participants' logistics plans. The local UPS Account Manager will be the participants' single point of contact for:

- > Operating plans and timelines
- > Pricing
- > Providing additional UPS contact points when local services are required

Participants who wish to engage UPS for some or all of their required logistics services for the Expo event are encouraged to reach out to their local UPS Account Manager.

In an effort to provide peace-of-mind for each participant, UPS will provide global pro-active coordination between each local participant and Expo 2020 in Dubai through a dedicated UPS Director of Business Development, already embedded within the Organiser.

11.3 What UPS Offers for the Logistics of Construction Materials

Participants may utilise UPS services during the construction phase as well as the event phase of Expo 2020 Dubai. Services that UPS is able to offer to participants include programme management, freight forwarding, small package/courier, warehousing, and distribution services. Participants are encouraged to communicate with their relevant UPS Account Manager for further details.

11.4 Onsite Services

Participants may request for additional onsite logistics support from UPS (on a rate card basis) via a Work Order. The completion of a Work Order will be based on the available resources. Figure 11.3 lists some of the logistics services offered by UPS onsite.

The detailed list of logistics services offered by UPS onsite, including the rate card and the applicable tariffs, will be available on the Participant Portal.

Figure 11.3 UPS' Onsite Logistics Services

- ✓ Small package/courier, same day delivery
- ✓ Freight forwarding (air, ocean, and road)
- ✓ Customs and brokerage services
- ✓ Storage and inventory management
- ✓ Distribution services
- ✓ Provision of mechanical handling equipment
- ✓ Provision of labour for unloading/loading vehicles on venue
- ✓ Storage of packaging materials and flight cases
- ✓ Decommissioning support or reverse logistics
- ✓ Supply chain insurance
- ✓ Onsite counters offering shipping services as well as receiving, packaging, and print services
- ✓ Assembly and other value-added services

11.5 CarbonNeutral Programme

Through its partnership with UPS, the Organiser offers participants the 'UPS CarbonNeutral' programme to give them the opportunity to mitigate the carbon footprint generated by the transport of their goods by purchasing certified offsets.

Carbon dioxide emissions are calculated for each shipment and UPS purchases and retires the carbon offsets. This provides participants the opportunity to contribute to projects across the globe. UPS partners with world-renowned third party verification and certification organisations to help validate this service.

Participants who wish to take part in the CarbonNeutral programme will pay a small incremental amount to offset the climate impact of the transport of their goods. Further details on the CarbonNeutral programme are available on the official website of UPS, which is provided in Supporting Resources.



Supporting Resources





The following resources can be accessed either from the Participant Portal or using the website addresses provided:

- › **Accreditation Guide**
- › **Assisted Pavilions Guide**
- › **ATA Carnet**
www.atacarnet.com/carnet-countries
- › **Customs Notice No. 1/2018**
<https://www.dubaicustoms.gov.ae/en/PoliciesAndNotices/Notices/CN%201-2018.pdf>
- › **Customs Policy No. 38/2011**
<https://www.dubaicustoms.gov.ae/en/PoliciesAndNotices/Policies/CP38E.pdf>
- › **Dubai Customs**
www.dubaicustoms.gov.ae/en
- › **Excise Tax Import Declaration User Guide**
[https://www.tax.gov.ae/pdf/Excise-Tax-Importers-\(Registered-Non-registered\)-User-Guide_English.pdf](https://www.tax.gov.ae/pdf/Excise-Tax-Importers-(Registered-Non-registered)-User-Guide_English.pdf)
- › **Forms and Templates Related to the Logistics and Customs Operation**
- › **Health and Safety Assurance Standards**
- › **Insurance Guide**
- › **ISPM 15**
<https://www.ippc.int/en/publications/640/>
- › **List of Customs Centres for Document Submission**
- › **List of Prohibited and Restricted Goods**
- › **Merchandise Accepted by ATA Carnet**
www.atacarnet.com/acceptable-carnet-merchandise
- › **Permitted and Duty-exempt Passenger Goods**
<https://www.dubaicustoms.gov.ae/en/eServices/ServicesForTravellers/CustomsDuties/Pages/PermittedItems.aspx>
- › **Prohibited Goods, Restricted Goods, and Controlling Authorities**
<https://www.dubaicustoms.gov.ae/en/eServices/ServicesForIndividuals/ViewCustomsInformation/Pages/Prohibited-and-Restricted-Goods.aspx>
- › **Rate Cards**
- › **Rented Pavilions Guide**
- › **RISE™ Sustainable Operations Standards and Guidelines**

- › **Security Delivery Access Protocols**
- › **Self-Build Pavilions Delivery Guide**
- › **Sustainability Policy**
- › **Training and FAQs on DMS**
- › **UPS Carbon Neutral Programme**
www.ups.com
- › **VAT and Excise Tax**
<https://www.tax.gov.ae/why-have-taxes.aspx>
https://www.tax.gov.ae/help_guides.aspx
www.tax.gov.ae/excise-price-list-and-process.aspx
- › **VAT Import Declaration User Guide**
[https://www.tax.gov.ae/pdf/VAT-Importers-User-Guide-\(Registered-Non-registered\)_English_1.pdf](https://www.tax.gov.ae/pdf/VAT-Importers-User-Guide-(Registered-Non-registered)_English_1.pdf)





expo2020dubai.com
🐦 [f](#) [@](#) [v](#) [in](#) @Expo2020Dubai
👤 ExpoStories